

mackworth

SA180



Weights and dimensions

SWL	: 180 kg
Unit weight	: 47 kg
Base weight	: 23 kg
Mast and boom weight	: 24 kg
A (height)	: 1,145 – 1,685 mm
B (length)	: 1,190 mm
C (internal width)	: 540 – 1,100 mm
D (external width)	: 680 – 1,050 mm
E (ground clearance)	: 33 mm
F (under bed clearance)	: 112 mm
G (Kneepad height)	: 430 – 555 mm
Turning circle	: 1,230 mm
Castor size	: 100 mm

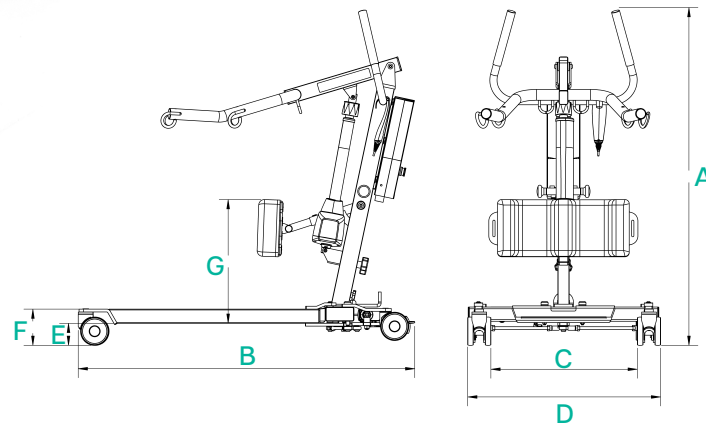

Details

Product code	: 1301SA-SA180
Drawing number	: 107750
GS1 code	: 5056408920179
Warranty	: 2 years
Sling connection	: Looped
Lift	: Electric (LA44 – 10 kN)
Leg opening	: Electric (LA23 – 1.8 kN)
Hand controls	: Wired electric hooked handset
Control box	: Standard (no screen)
Foot tray	: Removable (5.5 kg)
Duty cycle	: 15% use, 85% rest
Battery	: 24 V SLA, 2.9 Ah
Charging time	: 8 hours
Lifts per charge	: 30
IP rating (controls)	: IPX4
IP rating (battery)	: IPX5
Material	: Powdercoated steel, PU foam, vinyl PVC

Standards

ISO 10535:2006
 IEC 62366-1:2015
 EN ISO 15223-1:2016
 IEC 60601-1:2012
 IEC 60601-2:2014

This product is CE marked and complies with EU MDR 2017/745

Contact

Unit 4 Jubilee Way
 Grange Moor
 Wakefield
 United Kingdom
 WF4 4TD

+44 (0)1924 840100
 info@prismmedical.co.uk

