

Molift RgoSling

molift[®]
by Etac

User Manual - Bruksanvisning - Brukermanual - Brugervejledning - Käyttöopas -
Bedienungsanleitung - Gebruikershandleiding - Manuel d'utilisation - Manuale
per l'utente - Manual de usuario

BM40299 Rev. A 2021-02-17

RgoSling Toilet LowBack

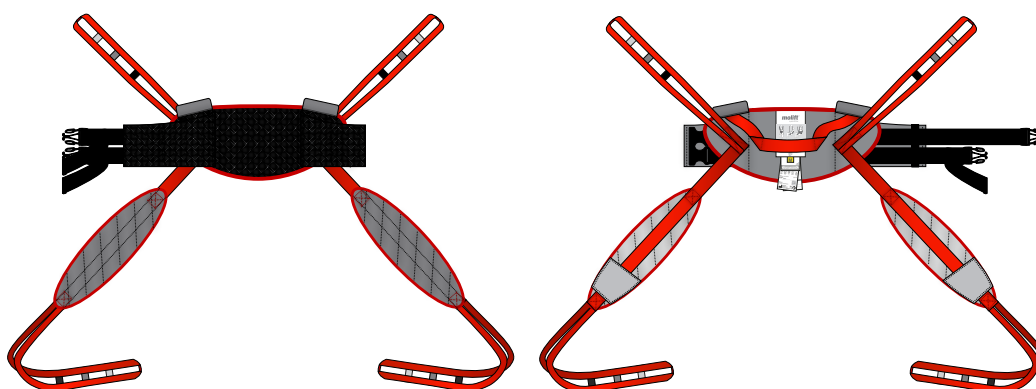

RgoSling Toilet HighBack

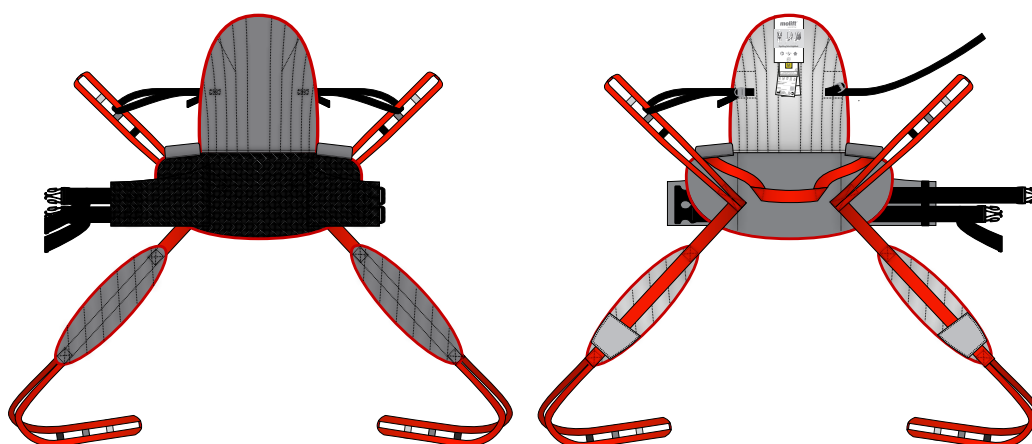

MD

CE

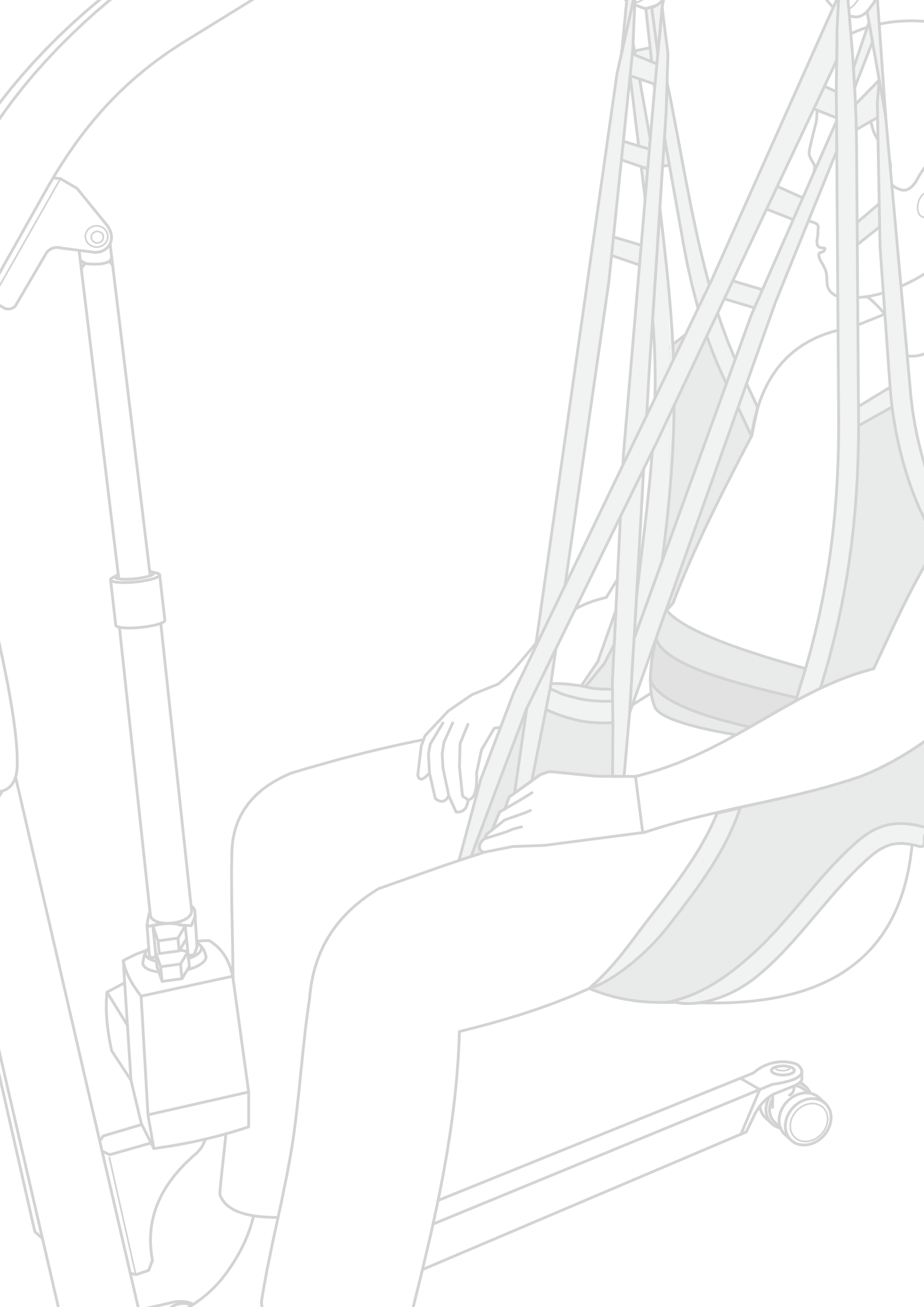



Contents

User manual - English -	4
Bruksanvisning - Svenska -	14
Brukermanual - Norsk -	24
Brugervejledning - Dansk -	34
Käyttöohje - Suomi -	44
Gebrauchsanweisung - Deutsch -	54
Handleiding - Nederlands -	64
Manual d'utilisation - Français -	74
Manual utente - Italiano -	84
Manual de usuario - Español -	94

English manual

Content

General.....	4
Test and Warranty	4
Safety Precautions	5
Inspection.....	5
Periodic inspection.....	5
Description.....	6
Etac Molift RgoSling Toilet LowBack	6
Etac Molift RgoSling Toilet HighBack	6
Care/Washing.....	6
Sling application	8
Sitting lifts.....	9
Lowering into sitting.....	9
Sling adjustment and checkpoints.....	10
Removing sling.....	11
Combination list	12
Slingguide	12
Troubleshooting	13

Test and Warranty

CE this product is CE-marked.

Etac Molift slings are tested by accredited test institutes and comply with the standards outlined in the Medical Devices Directive for Class 1 products MDR (EU) 2017/745. The slings fulfil the requirements specified in the EN ISO 10535 standard.

Warranty: Two years for material and manufacturing defects with correct use.

For more details on Etac Molift's range of slings and lifts visit www.molift.com

General

Thank you for choosing a sling from Molift by Etac.

The manual must be read thoroughly to avoid injuries or damage when handling and using the product.

In this manual the user is the person being lifted. The assistant is the person operating the sling.



This symbol appears in the manual together with text. It indicates a need for caution when the safety of the user or assistant may be at risk

Etac continuously makes improvements to the products. We therefore reserve the right to modify the products without prior notice.



Visit www.molift.com for more information, advice and any documentation updates.

We cannot be held responsible for any printing errors or omissions.

Safety Precautions

To be aware of



The manual for both lift and sling must be read thoroughly before use to avoid injury when handling and using the product.

It is important that the sling has been tested with the individual user and for the intended lifting situation. Make a decision on whether one or more assistants are required.

Plan the lifting operation in advance to ensure that it is as safe and smooth as possible. Remember to work ergonomically.

Assess the risks and take notes. You as a carer are responsible for the safety of the user.



Never lift a user higher from the starting point than what is necessary to carry out a lift. Never leave the user unattended in a lifting situation



Always check

- that the user has the required ability for the sling in question
- that the model, size and material are suitable
- that the sling is suitable for the lift/suspension to be used.
- It is important to check that the strap loops are correctly attached to the suspension hooks before lifting the user.
- Make sure wheels on the wheelchair, bed or bunk are locked when necessary during the transfer process.

Inspection

The sling must be inspected regularly, preferably prior to each lifting operation but especially after it has been washed.

- Check to ensure that there is no wear or damage to seams, fabric, straps and loops.



Never use a faulty or damaged sling as it can break and cause personal injury. Destroy and discard damaged and old slings



The sling should not be stored in direct sunlight.

Periodic inspection

Periodic inspection must be carried out at least

every 6 months. More regular inspection may be required if the sling is used or washed more often than is normal. See the periodic inspection form at www.molift.com

Description

Etac Molift supplies a wide selection of slings for different types of transfers. The Molift RgoSling is designed to distribute even weight and pressure to make it as comfortable as possible.

There is a guide handle to help position users in the correct sitting position and it is used only when users are in lifting mode.

The Molift RgoSling is developed to be combined with a 4-point suspension but the sling also works with a 2-point suspension. See the combination list for the correct sling and suspension combination.

The Molift RgoSling Toilet is available in sizes XXS – XXL, in padded polyester.

Etac Molift RgoSling Toilet LowBack

has a low back, split leg support with a wide opening. The sling can be used for lifting to and from a sitting position.

Etac Molift RgoSling Toilet HighBack

has a high back, split leg support with a medium opening. The sling has headsupport. The sling can be used for lifting to and from a sitting position.

The RgoSling Toilet LowBack and RgoSling Toilet HighBack are not suitable for persons with low muscle tone. There is a high risk of user with low muscle tone slipping out of the sling, because the sling has a wide opening.

The product has an expected service life of 1 to 5 years under normal use. The service life of the product varies depending on usage frequency, materials, loads and how often it is washed.

- A1. Product label
- A2. (01) EAN-code
xxxxxxxxxxxxxxxx
- (21) Serial number
xxxxxxxx
- A3. QR-code
- A4. Label: Periodic inspection
- A5. Label: User name
- A6. Upper strap loop
- A7. Waist belt
- A8. Padding
- A9. Guide handle, side
- A10. Guide handle, back
- A11. Head support adjustment
- A12. Leg support
- A13. Application pocket, leg
- A14. Lower strap loops
- A15. Headrest
- A16. Symbol: Read the manual before use
- A17. Symbol: Max. user weight
- A18. Symbol: This side of the product is turned upward and outward
- A19. Symbol: Fold out for more information

Care/Washing

Read the care instructions on the product.

1. Water washable slings can be washed at temperatures ranging from 60 to 85° C degrees.
-  Washing at higher temperatures wears out the material faster.
2. Tumble drying, max 45° C.
Can be autoclaved at 85° C for 30 minutes
3. Do not dryclean.
4. Do not bleach.
5. Do not iron.

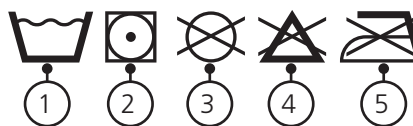

Symbols:



Manufacturer



This way up, this side is outside



Date of manufacture.
YYYY-MM-DD
(year/month/date)



Max user weight



CE marked



Medical Device



Refer to user manual

A

RgoSling Toilet LowBack

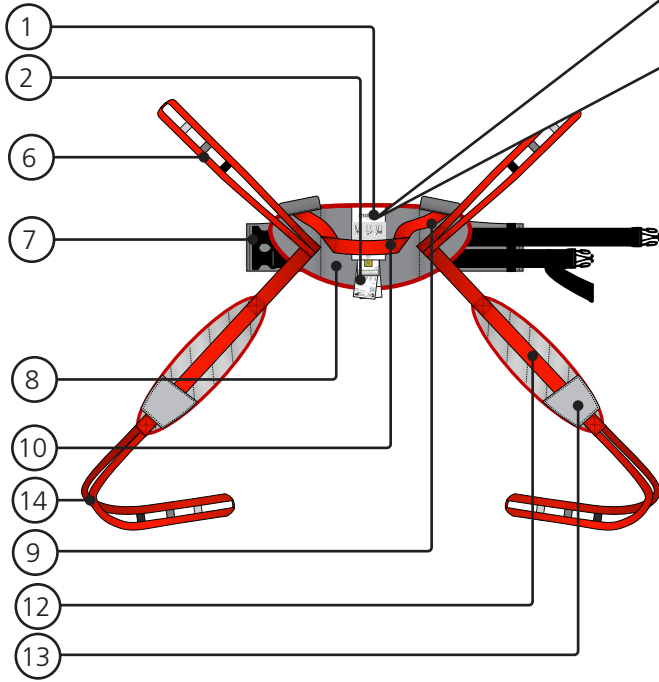

RgoSling Toilet HighBack

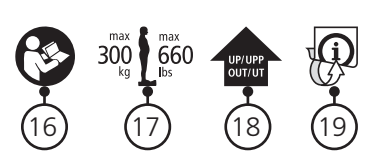
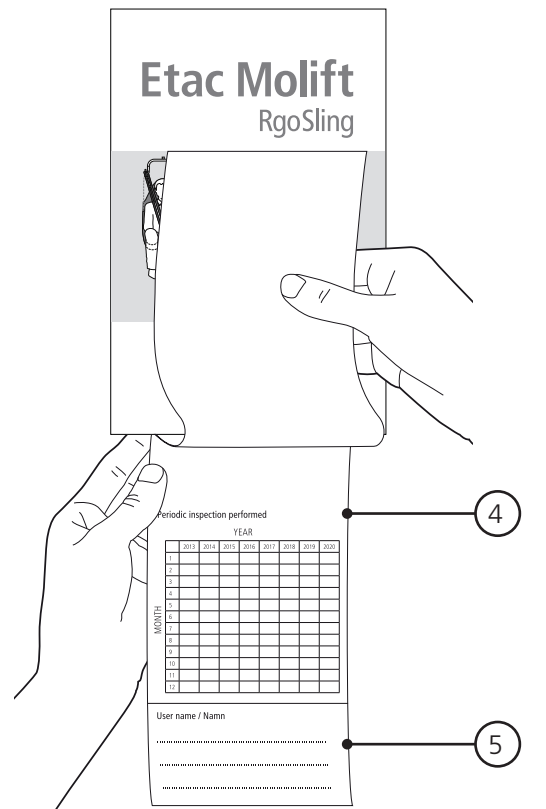
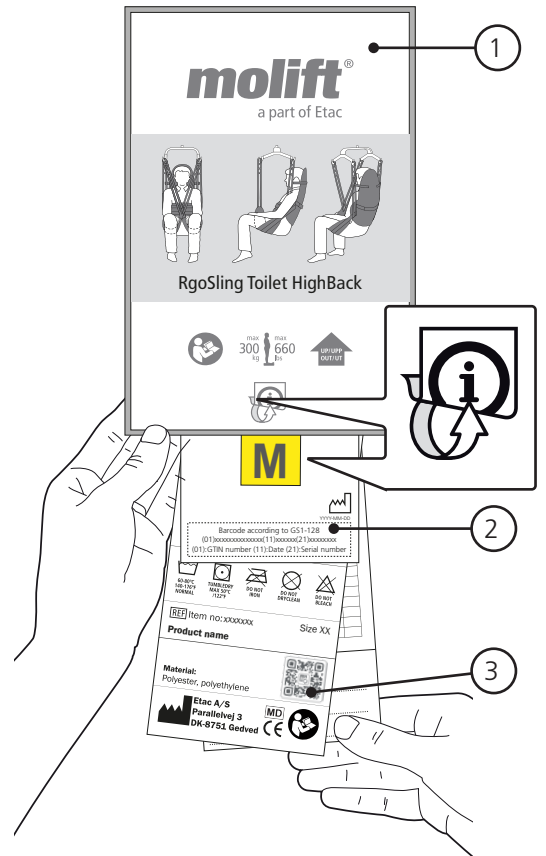
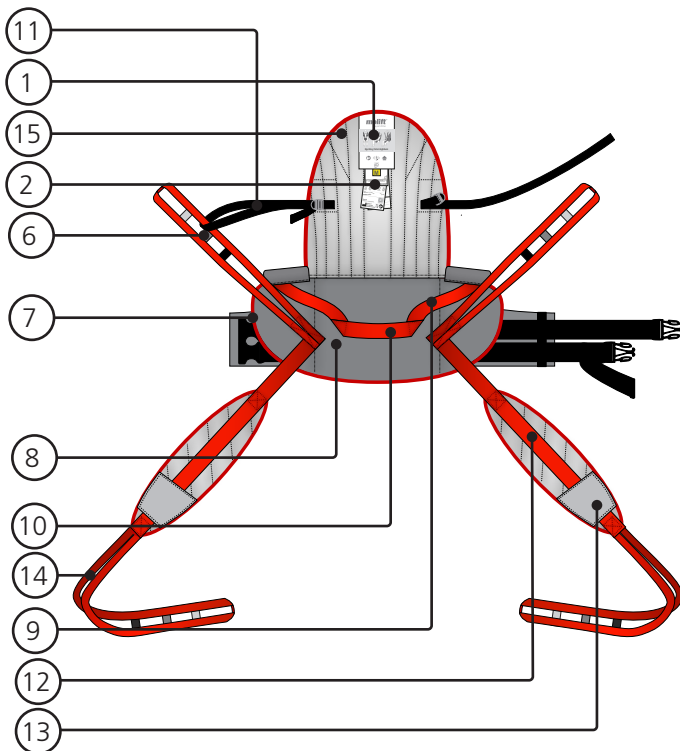

B

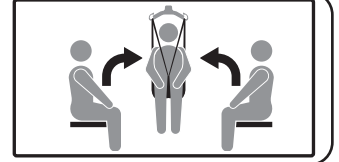

Sling application

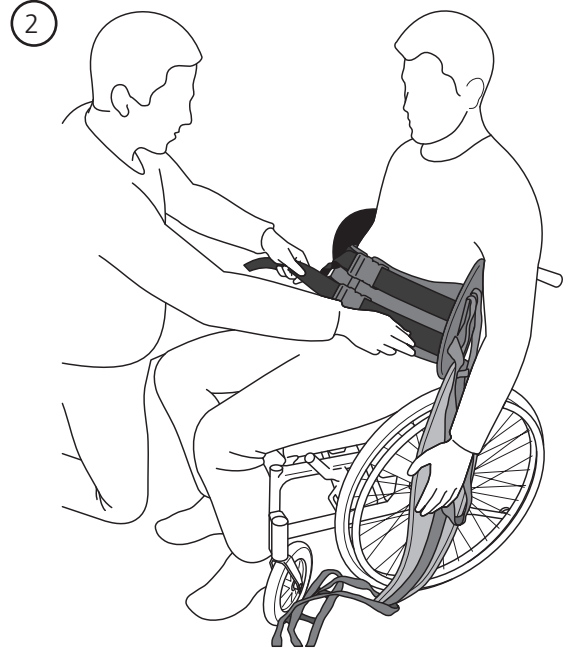
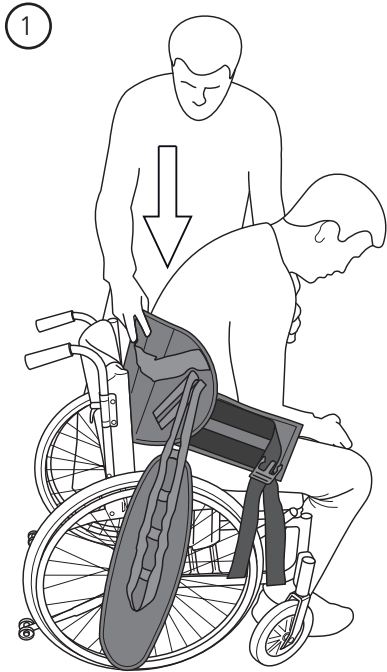

B1. Prepare the User by unbuttoning his/her pants. Hold the sling with one hand and use the other hand to support the user. Slide the sling down behind the user's back. Place the sling approximately in waist height on the back.

B2. Fix the waist belt and tighten. Make sure that trousers are accessible.

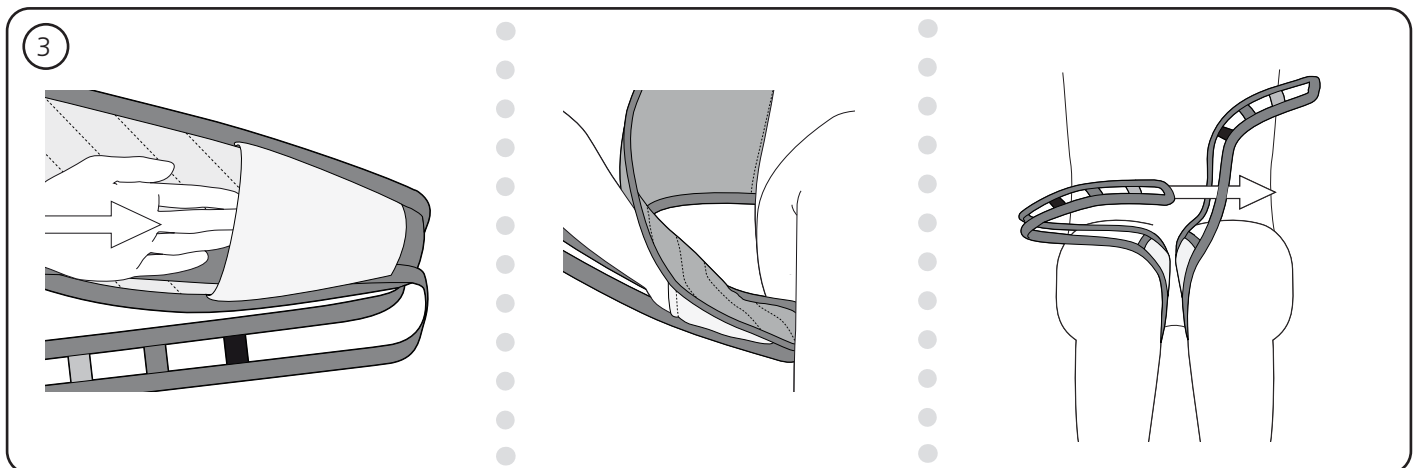

B3. Position the leg supports under the user's thighs. The pocket at the outer end of the leg support facilitates application. Cross the leg loops by pulling one of the loops through the other.

Sitting lift

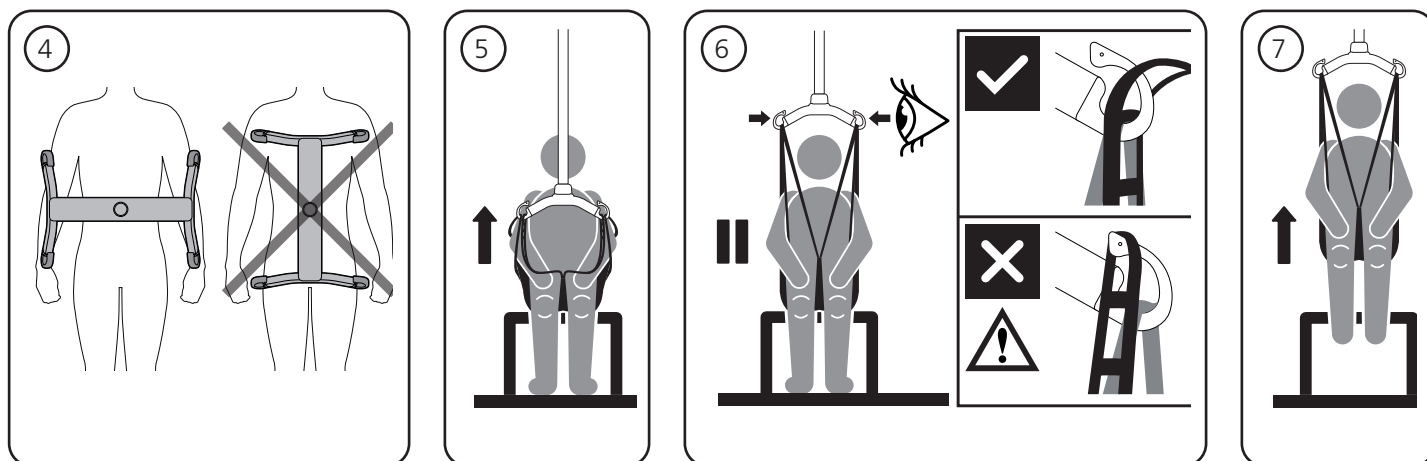

- B4. The suspension must always be positioned across the user, to prevent the user from unintentionally sliding out of the sling.
 B5. Suspend the sling in the suspension's hooks.
 B6. Stretch the sling straps without lifting the user. Check that the sling is correctly fitted around

- the user and that the strap loops are correctly fitted to the suspension hooks.
 B7. Lift the user no higher than necessary. Remember that wheels on a mobile lift must NOT be locked.

Lowering into sitting

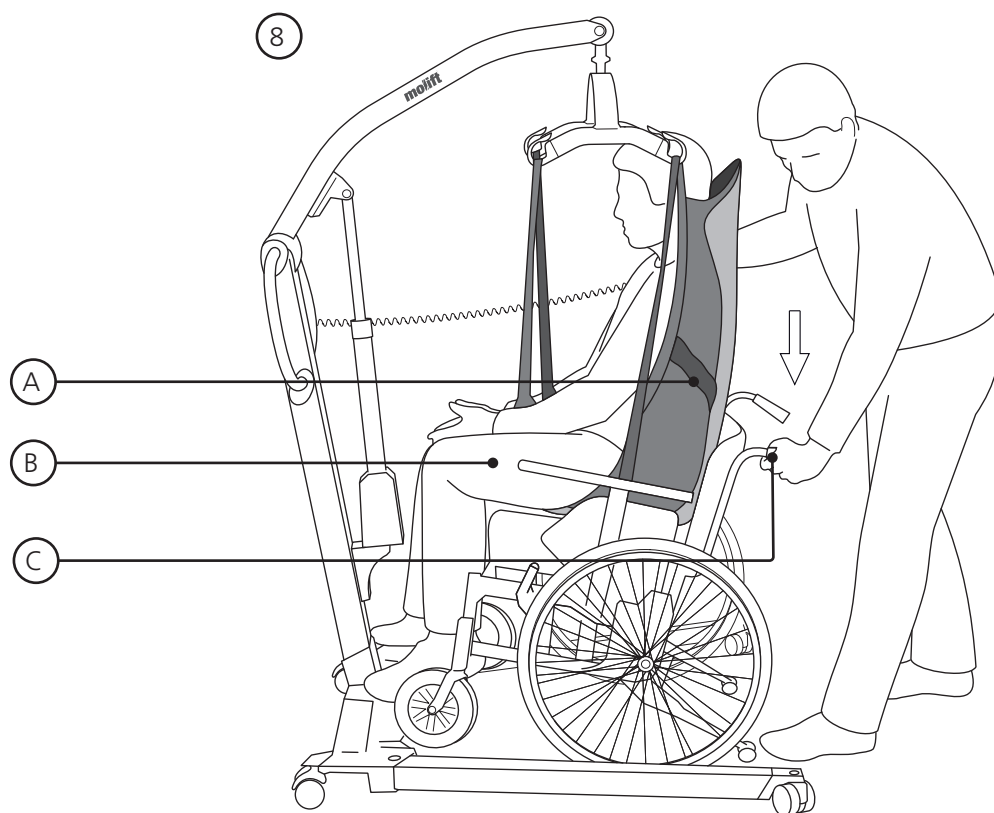

- B8. When transferring the user into sitting, the following techniques can be used when lowering the user as far back into the seat as possible:

- A. Position the user with the help of the steering handle
 B. Push gently on the users knees
 C. Tilt the seat backwards

C

Sling adjustment and checkpoints

RgoSling Toilet LowBack

- C1. Make sure suspension is away from the users face
- C2. Waist belt locked and tightened
- C3. Cross suspension loops
- C4. Leg support placed correctly
- C5. Backrest placed in correct height

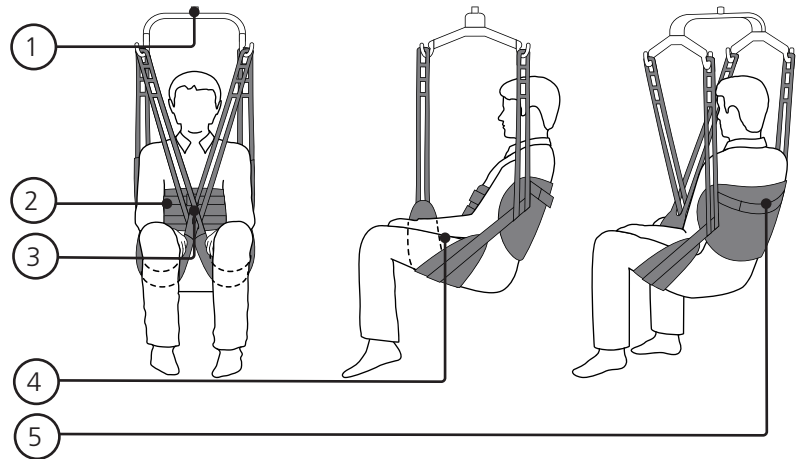

RgoSling Toilet HighBack

- C6. Make sure suspension is away from the users face
- C7. Waist belt locked and tightened
- C8. Cross suspension loops
- C9. Leg support placed correctly
- C10. Backrest placed in correct height
- C11. Head Support adjustment

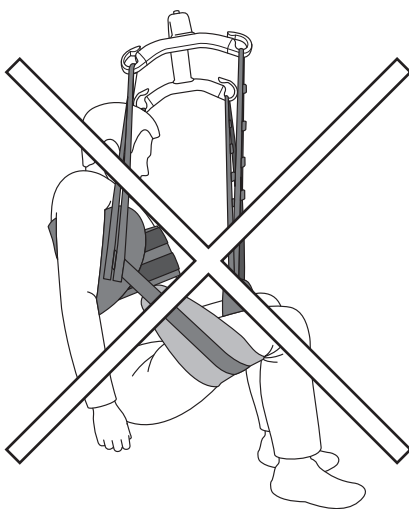
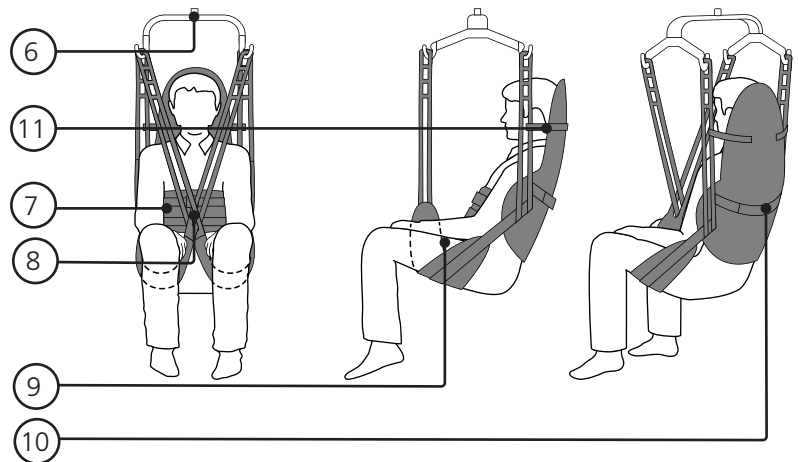

C12. Incorrect positioning of the sling. The backpiece is fitted too high and legsupport too far forward. Situation can also occur if the user does not have enough muscle tone.

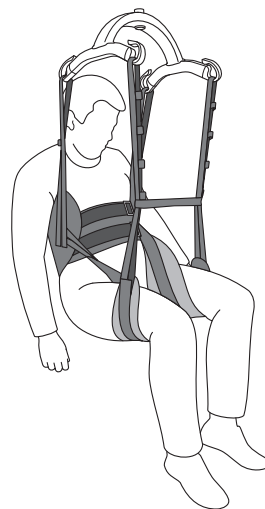

C13. Alternative legsupport placement using extension loops in addition.

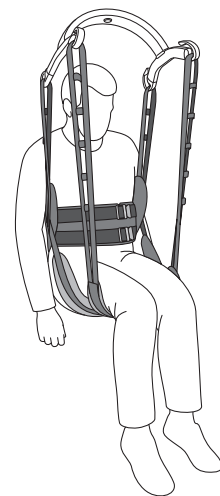

C14. Alternative legsupport placement, with both legsupports under both legs

D

Removing Sling

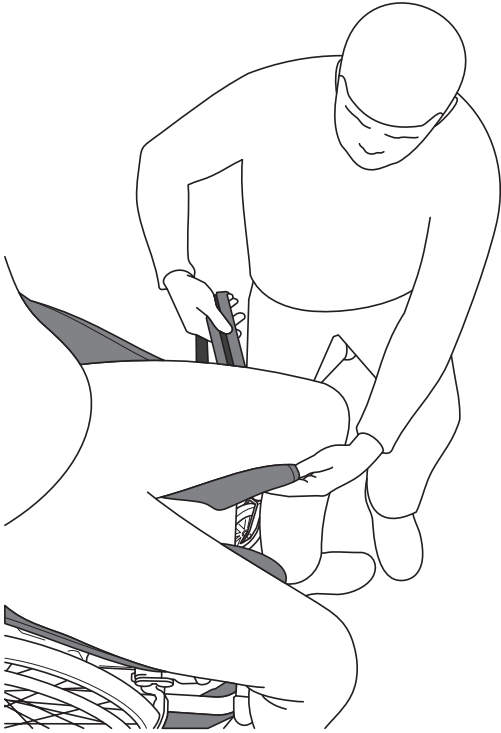



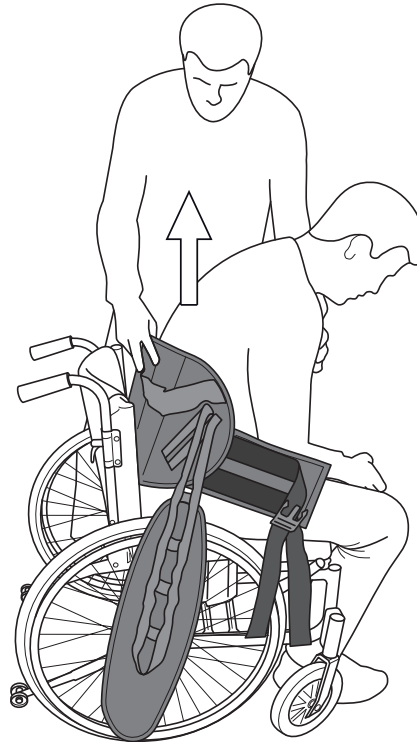









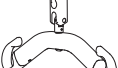

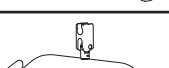

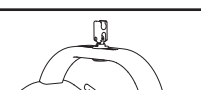

D1. Remove the leg support by folding the leg support under the users thigh and pull out.

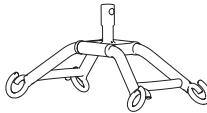
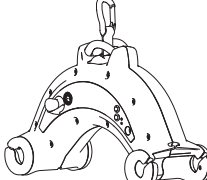

D2. Stand next too the chair and lean the user forward while supporting with one hand. Pull the sling away with the other hand, and lean the user back in the chair. If you pull the sling up hard, the user may fall forwards and be injured. Always hold one hand around the user.

Combination list

Suspension		RgoSling Toilet Lowback / RgoSling Toilet Highback		
		XXS - S	S - L	L - XXL
Mover 180				
	2-pt Small	✓		
	2-pt Medium	✓	✓	
	2-pt Large		✓	
	4-pt Medium	✓	✓	✓
	4-pt Large		✓	✓
Mover 205				
	2-pt Small	✓		
	2-pt Medium	✓	✓	
	2-pt Large		✓	
	4-pt Medium	✓	✓	✓
	4-pt Large		✓	✓
Mover 300				
	4-pt Medium	✓	✓	✓
	4-pt Large		✓	✓
Partner 255				
	4-pt Medium	✓	✓	✓
	4-pt Large		✓	✓

Suspension		RgoSling Toilet Lowback / RgoSling Toilet Highback		
		XXS - XS	S - L	XL - XXL
Smart				
	4-pt Medium	✓	✓	✓
Nomad				
	4-pt Medium	✓	✓	✓
Nova				
	2-pt Small	✓		
	2-pt Medium	✓	✓	
	2-pt Large		✓	
	4-pt Medium		✓	✓
	4-pt Large			✓

Slingguide

The size to choose depends partly on the user's weight, function and body circumference/size. SWL (Safe Working Load) is 300 kg.

Size	Weight (Kg)
XXL	230-300
XL	160-240
L	90-160
M	45-95
S	25-50
XS	17-25
XXS	12-17

Troubleshooting

Symptom	Possible Cause/Action
The sling does not fit the user.	Wrong sling size. Try other size.
	The sling is too small when the leg supports do not reach halfway around the inner thigh and the suspension is too close to the user's face. Try other size.
	The sling is not correctly positioned. Pull the sling enough down at the back when fitting it.
All the straps does not lift at the same time.	If the sling straps lift unevenly, it means that the sling can slide up at the back which can lead to the user sliding down in the opening of the sling. Make sure that the leg supports are positioned correctly on the thighs.
User is sliding through/out of the sling.	The sling is not connected correctly according to individual prescription.
	The user is wearing to slippery clothes. Remove or change some of the clothing.

EN

SV

NO

DA

FI

DE

NL

FR

IT

ES

Manual Svenska

Innehåll

Allmänt.....	14
Testning och garanti.....	14
Försiktighetsåtgärder.....	15
Tillsyn.....	15
Periodisk inspektion.....	15
Beskrivning.....	16
Etac Molift RgoSling Toilet LowBack.....	16
Etac Molift RgoSling Toilet HighBack.....	16
Skötsel / tvätt.....	16
Applicering av sele.....	18
Lyft.....	19
Nedsänkning till sittande position.....	19
Justering av selen samt kontrollpunkter....	20
Ta bort selen.....	21
Kombinationslista.....	22
Selguide.....	22
Felsökning.....	23

Testning och garanti

CE Denna produkt är CE-märkt..

Etac Molifts lyftselar är testade av ackrediterade testinstitut och uppfyller kraven enligt standarderna i Medicintekniska direktivet för klass 1-produkter MDR (EU) 2017/745). Selarna uppfyller kraven enligt EN ISO 10535..

Garanti: Två år för material och tillverkningsfel vid korrekt användning.

Mer information om Etac Molifts sortiment av selar och lyftar, gå in på www.etac.se.

Allmänt

Tack för att du valt en lyftsele från Molift by Etac.

För att undvika skador vid hantering och användning skall denna manual läsas igenom.

I den här manualen är Brukaren den person som lyfts. Assistenten är den person som applicerar selen.



Den här symbolen förekommer i manualen tillsammans med text. Den indikerar behov av försiktighet när brukarens eller hjälparens säkerhet kan äventyras.

Etac förbättrar fortlöpande sina produkter. Vi förbehåller oss därför rätten att ändra produkterna utan föregående meddelande.



Besök www.etac.se för mer information, råd och eventuella uppdateringar av dokumentation.

Vi reserverar oss för feltryck och ofullständigheter.

Försiktighetsåtgärder



För att undvika skador vid hantering och användning ska alltid manual för både lyft och lyftsele läsas igenom noga före användning..

månad. Tätare inspektioner kan krävas om selen används eller tvättas oftare än normalt. Se protokoll för periodisk inspektion på www.etac.se.

Det är viktigt att selen är utprovad för den enskilda brukaren och den avsedda lyftsituationen. Gör en bedömning om det behövs en eller flera assistenter.

Planera lyftmomentet före lyft, så att det sker så tryggt och smidigt som möjligt. Tänk på att arbeta ergonomiskt.

Gör en riskbedömning och dokumentera. Som vårdgivare är du ansvarig för brukarens säkerhet



Lyft aldrig en brukare högre från underlaget än vad som är nödvändigt för lyftets genomförande. Lämna aldrig en brukare utan tillsyn i en lyftsituation.



Kontrollera alltid:

- att brukaren har den funktion som krävs för den aktuella selen
- att modell, storlek och material passar
- att selen passar för den lyft/lyftbygel som ska användas.
- Det är viktigt att kontrollera att bandöglorna sitter rätt på upphängningskrokarna innan brukaren lyfts från underlaget.
- Se till att hjulen på rullstol, säng, brits etc. är låsta när så krävs under förflyttningen.

Tillsyn

Selen ska kontrolleras regelbundet, helst före varje användning, men var särskilt noggrann efter att den tvättats.

- Kontrollera så att inga förslitningar eller skador finns på sömmar, tyg, band och öglor.



Använd aldrig en trasig eller skadad lyftsele, den kan gå sönder och orsaka personskador. Kassera skadade eller slitna selar.



Selen bör ej förvaras i direkt solljus.

Periodisk inspektion

Periodisk inspektion skall utföras minst var 6:e

Beskrivning

Etac Molift erbjuder ett brett sortiment av lyftselar för olika slags förflyttningar. Etac Molift RgoSling är utformad för att ge en jämn vikt- och belastningsfördelning för att vara så bekväm som möjligt.

För att positionera brukaren till rätt sittande position finns det styrhandtag som används endast när brukaren är i lyft läge.

Etac Molift RgoSling är utvecklad för att kombineras med 4-punktsbygel men selen fungerar även bra med 2-punksbygel. Se kombinationslista för korrekt kombination av sele och bygel.

Molift RgoSling Toilet finns som polstrad modell i polyestertyg i storlek XXS – XXL.

Etac Molift RgoSling Toilet LowBack

Etac Molift RgoSling Toilet LowBack har låg rygg och delade benstöd med mediumskärning. Selen kan användas vid lyft till och från sittande ställning..

Etac Molift RgoSling Toilet HighBack

Etac Molift RgoSling Toilet HighBack har hög rygg och delade benstöd med mediumskärning. Selen har ett huvudstöd. Selen kan användas vid lyft till och från sittande ställning.

RgoSling Toilet LowBack och RgoSling Toilet HighBack är inte lämpliga för personer med låg tonus. Det finns stor risk för att patienter med låg tonus glider ur selen eftersom den har en vid öppning.

Produkten har en förväntad livslängd på 1-5 år vid normal användning. Livslängden på produkten varierar beroende på användningsfrekvens, material, belastning samt hur ofta den tvättas.

- A1. Produktetikett
- A2. (01) EAN-kod
xxxxxxxxxxxxxxxxxx
(21) Serienummer
xxxxxxxx
- A3. QR-kod
- A4. Etikett: Periodisk inspektion
- A5. Etikett: Brukarnamn
- A6. Övre bandögla
- A7. Midjebälte
- A8. Polstring
- A9. Styrhandtag sida
- A10. Styrhandtag bak
- A11. Justering för huvudstöd
- A12. Benstöd
- A13. Appliceringsficka ben
- A14. Nedre bandöglor
- A15. Huvudstöd
- A16. Symbol: Läs manual före användning
- A17. Symbol: Max brukarvikt
- A18. Symbol: Denna sida av produkten vänds uppåt och utåt
- A19. Symbol: Veckla ut för mer information

Skötsel / tvätt

Läs skötselinstruktionen på produkten.

1. Selar med angiven vattentvätt kan tvättas med temperatur från 60 till 85 °C.



Vid tvätt i högsta temperatur sker en snabbare förlitning av materialet.

2. Torktumling max 45 °C.
Kan autoklaveras vid 85 grader i 30 min
3. Får inte kemtvättas.
4. Får inte klorblekas
5. Får inte strykas.

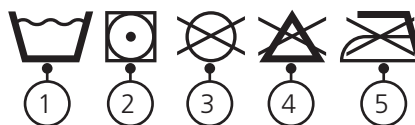

Symboler:



Tilverkare



Denna sida upp, denna sida utåt



Tillverkningsdatum.
ÅÅÅÅ-MM-DD
(år/månad/dag)



Max. brukarvikt
(säker arbetsbelastning)



CE-märkt



Medicinteknisk produkt



Se manual

A

RgoSling Toilet LowBack

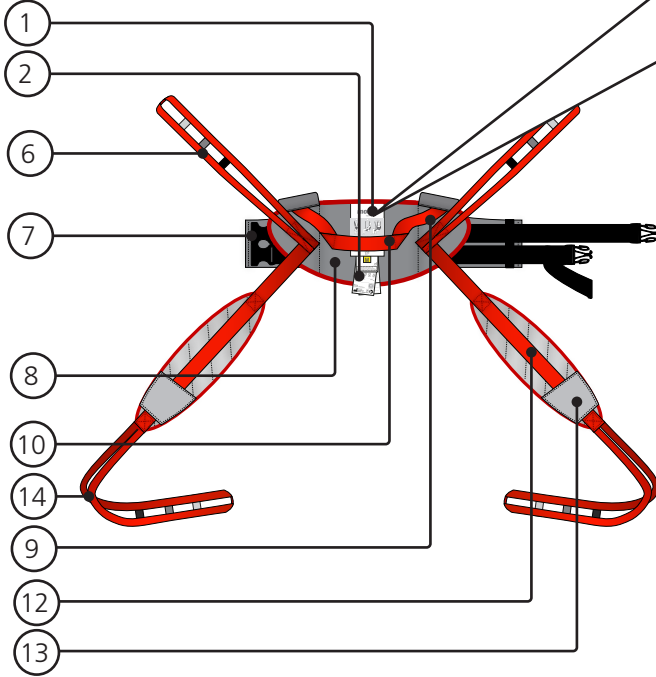

RgoSling Toilet HighBack

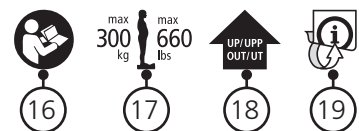
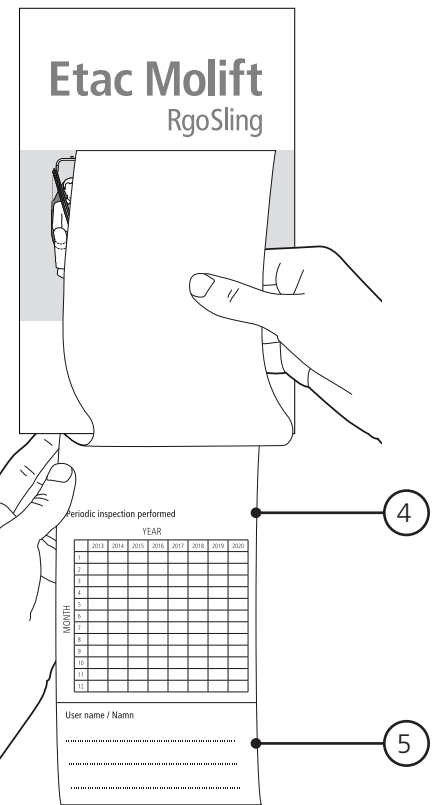
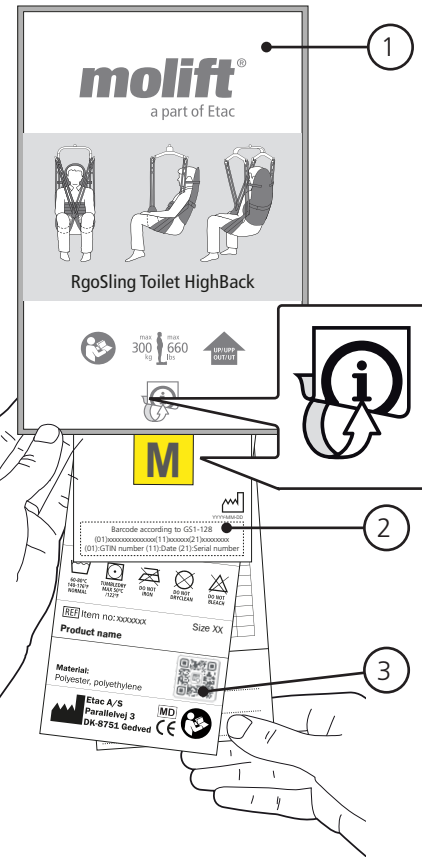
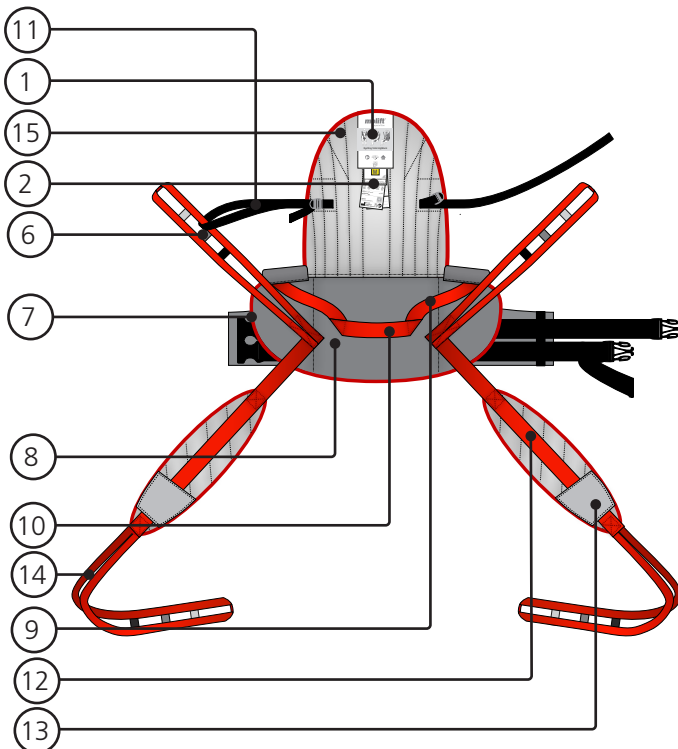

B

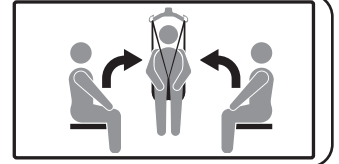

Applicering av sele

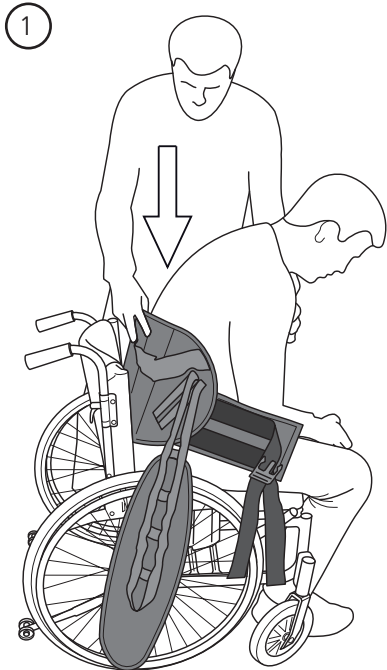

B1. Förbered brukaren genom att knäppa upp hans/hennes byxor. Håll lyftselen med ena handen och använd den andra handen för att stödja patienten. För ner lyftselen bakom brukarens rygg. Placera selen ungefär i midjehöjd bak.

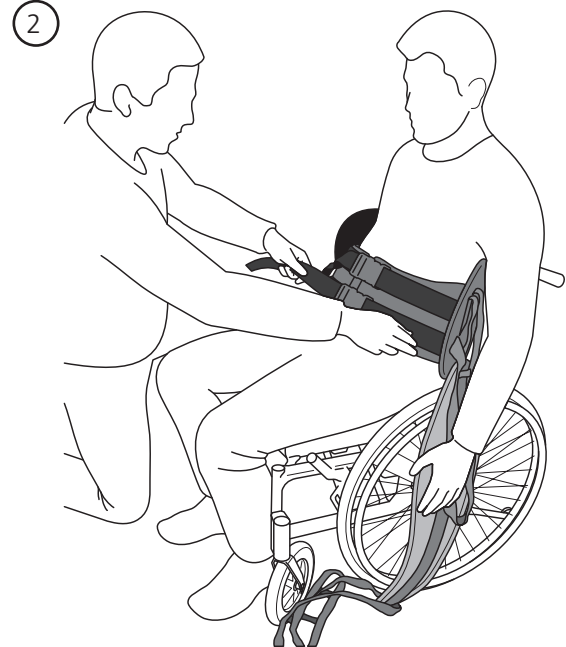

B2. Fixera midjebältet och dra åt. Se till att det går att komma åt byxorna.

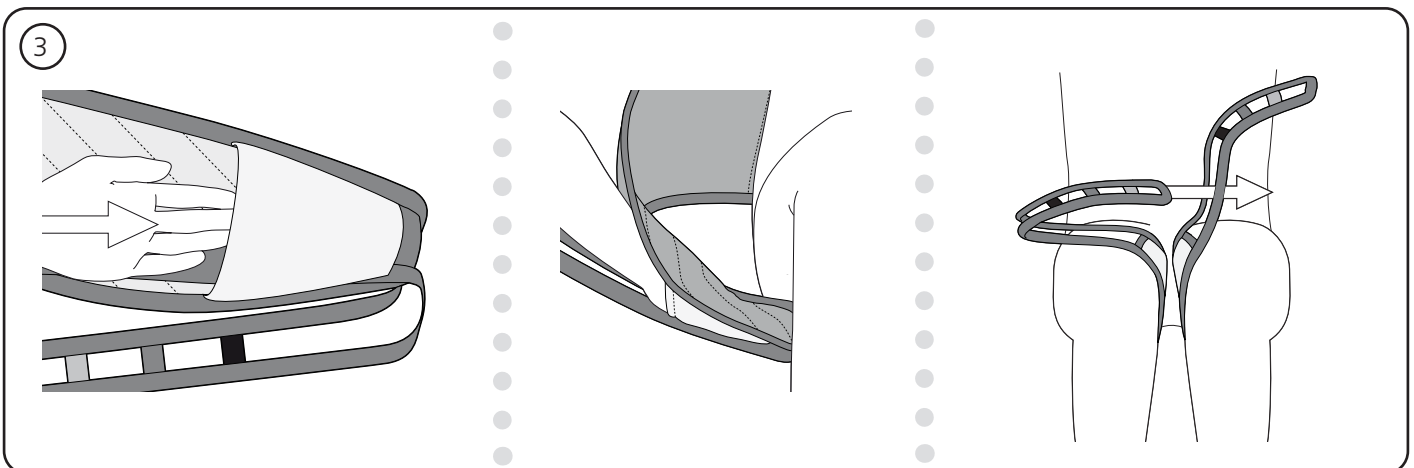

B3. Placera benstöden under brukarens lår. Fickan längst ut på benstödet underlättar appliceringen. Korsa benöglorna genom att dra den ena öglan genom den andra.

Lyft

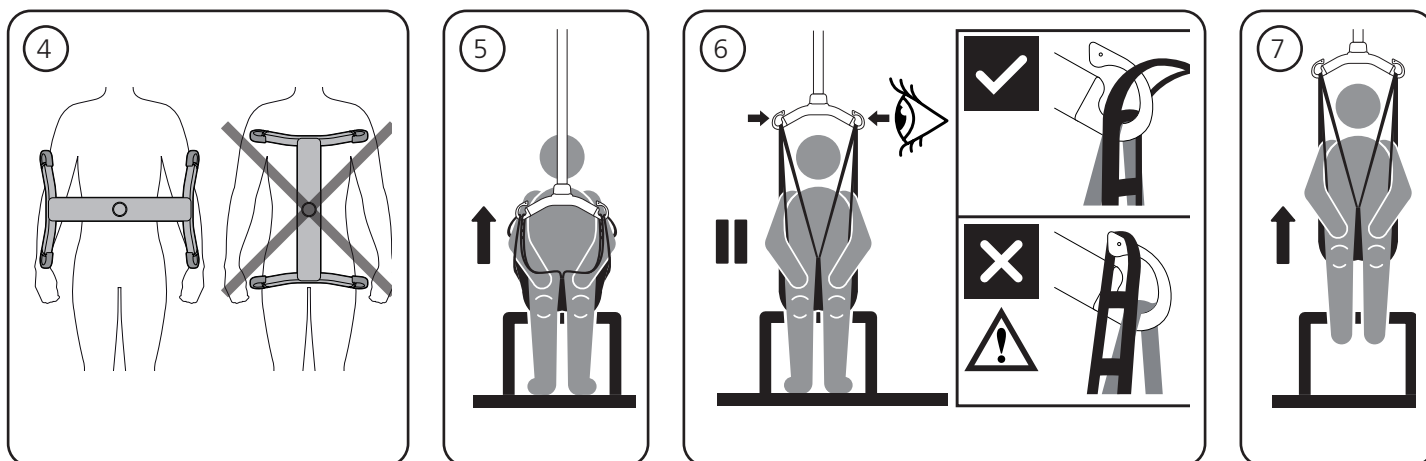

B4. Lyftbygeln skall alltid ställas på tvären över brukaren för att förhindra att brukaren oavsiktligt glider ur lyftselen.

B5. Häng upp selen i lyftbygelns krokar

B6. Sträck selens band utan att brukaren lyfts. Kontrollera att selen är rätt applicerad på

brukaren och att bandöglorna sitter rätt i bygelkrokarna.

B7. Lyft brukaren, dock inte högre än nödvändigt. Kom ihåg att hjulen INTE ska låsas på en mobil lyft.

Nedsänkning till sittande position

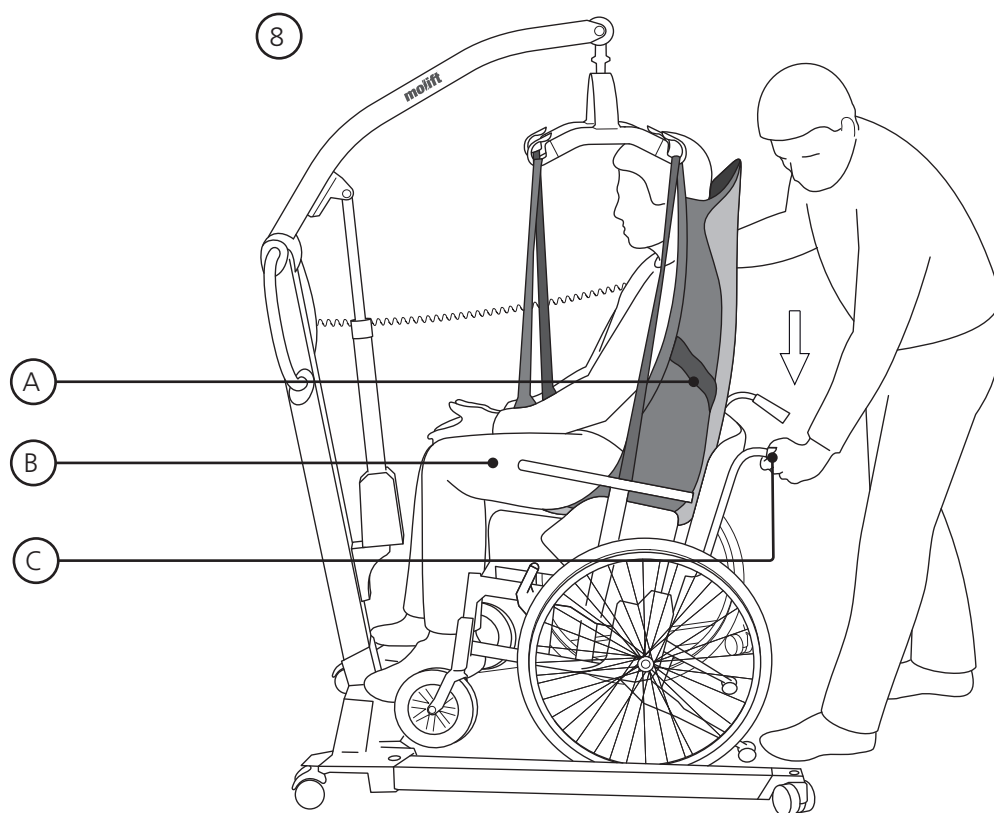

B8. När brukaren sänks ned till sittande position kan följande tekniker användas för att brukaren ska hamna så långt bak på sitsen som möjligt:

A. Placera brukaren med hjälp av styrhandtaget.

B. Tryck försiktigt på brukarens knän.

C. Luta sätet bakåt.

C

Justering av selen samt kontrollpunkter

RgoSling Toilet LowBack

- C1. Se till att brukaren inte har upphängningsanordningen nära ansiktet
- C2. Låst och åtdraget midjebälte
- C3. Korsa upphängningsöglorna
- C4. Se till att benstödet är korrekt placerat
- C5. Se till att ryggstödet är placerat i rätt höjd

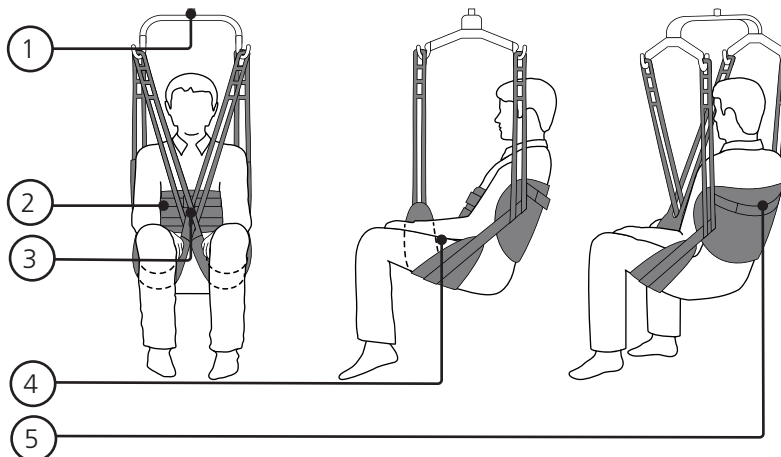

RgoSling Toilet HighBack

- C6. Se till att brukaren inte har upphängningsanordningen nära ansiktet
- C7. Låst och åtdraget midjebälte
- C8. Korsa upphängningsöglorna
- C9. Se till att benstödet är korrekt placerat
- C10. Se till att ryggstödet är placerat i rätt höjd
- C11. Justering för huvudstöd

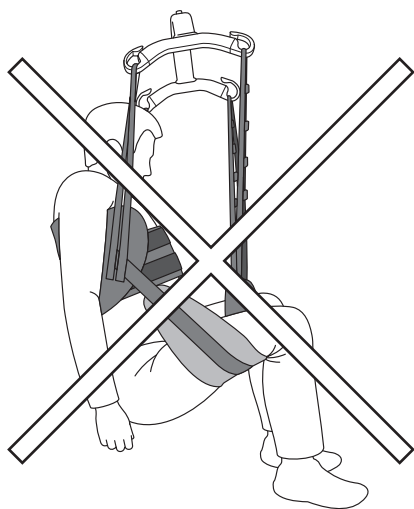
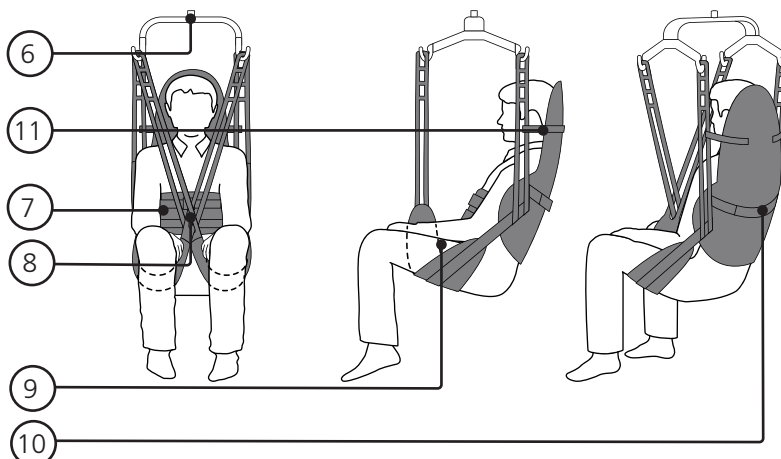

C12. Felaktig placering av selen. Både ryggdelen och benstöden sitter för långt upp/fram. En sådan här situation kan också inträffa om brukaren inte har tillräcklig tonus.

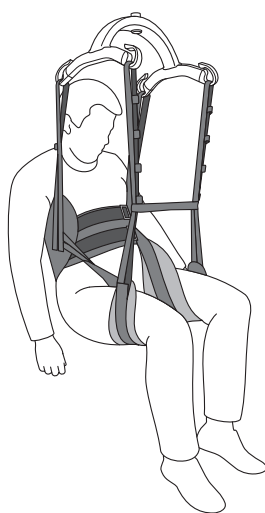

C13. Alternativ benstödsplacering med hjälp av extra förlängningsband..

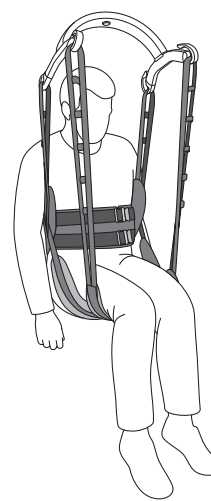

C14. Alternativ benstödsplacering med båda benstöden under båda benen.

D

Ta bort selen

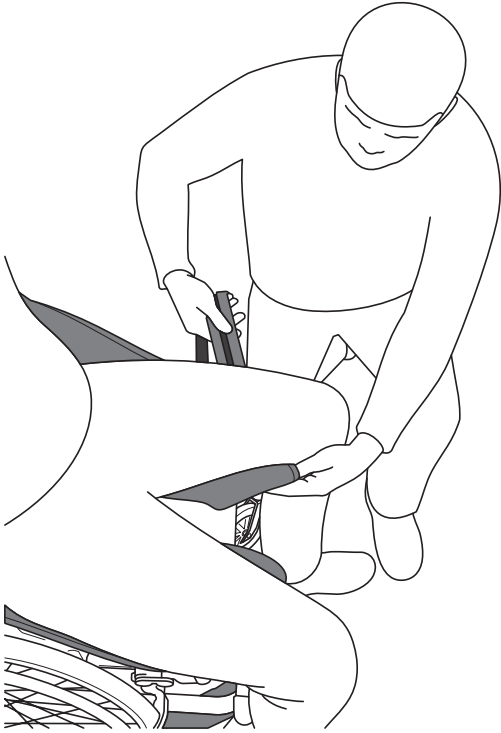



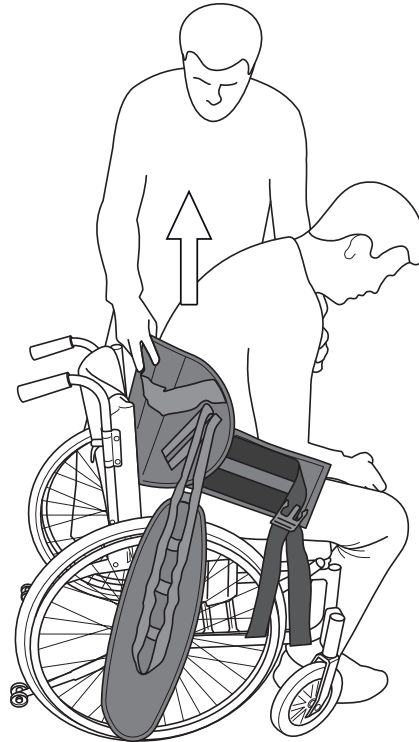







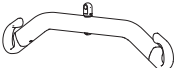

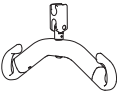
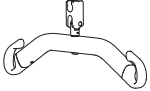
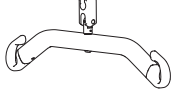

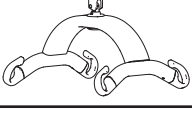

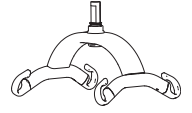
D1. Ta bort benstödet genom att vika benstödet under själva selen och användarens lår och dra ut det.

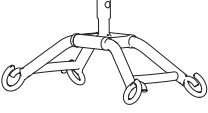
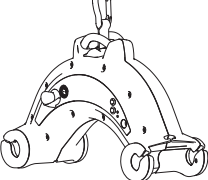

D2. Stå bredvid stolen och luta brukaren framåt samtidigt som du stöder brukaren med en hand. Dra selen uppåt med den andra handen och luta sedan brukaren tillbaka i stolen. Om du drar upp selen med alltför stor kraft kan användaren falla framåt och skadas. Stöd alltid brukaren med en hand.

Kombinationslista

Bygel		RgoSling Toilet Lowback / RgoSling Toilet Highback		
		XXS - S	S - L	L - XXL
Mover 180				
	2-pt Small	✓		
	2-pt Medium	✓	✓	
	2-pt Large		✓	
	4-pt Medium	✓	✓	✓
	4-pt Large		✓	✓
Mover 205				
	2-pt Small	✓		
	2-pt Medium	✓	✓	
	2-pt Large		✓	
	4-pt Medium	✓	✓	✓
	4-pt Large		✓	✓
Mover 300				
	4-pt Medium	✓	✓	✓
	4-pt Large		✓	✓
Partner 255				
	4-pt Medium	✓	✓	✓
	4-pt Large		✓	✓

Bygel		RgoSling Toilet Lowback / RgoSling Toilet Highback		
		XXS - XS	S - L	XL - XXL
Smart				
	4-pt Medium	✓	✓	✓
Nomad				
	4-pt Medium	✓	✓	✓
Nova				
	2-pt Small	✓		
	2-pt Medium	✓	✓	
	2-pt Large		✓	
	4-pt Medium		✓	✓
	4-pt Large			✓

Selguide

Vilken storlek man ska välja beror dels på personens vikt, funktion, och på kroppsomfånget/storleken. SWL (Safe Working Load) är 300 kg.

Storlek	Vikt (Kg)
XXL	230-300
XL	160-240
L	90-160
M	45-95
S	25-50
XS	17-25
XXS	12-17

Felsökning

Symptom	Möjlig orsak/åtgärd
Selen passar inte brukaren.	Fel storlek på selen. Prova med en annan storlek.
	Lyftselen är för liten när benstöden inte når runt minst halva lårens insida och upphängningen kommer för nära ansiktet. Prova med en annan storlek.
	Lyftselen är inte korrekt placerad. Dra ned selen tillräckligt långt i ryggen vid applicering.
Alla band lyfter inte samtidigt.	Lyfter lyftselsens band ojämnt innebär det att lyftselen kan glida upp i ryggen vilket får till följd att brukaren glider ner i lyftselsens hål. Se till att benstöden är korrekt placerade på låren.
Brukaren glider igenom/ur selen.	Selen är inte kopplad korrekt enligt den individuella förskrivningen.
	Brukaren har på sig alltför hala kläder. Byt eller ta av något av klädesplaggen.

Norsk manual

Innhold

Generelt.....	24
Test og Garanti.....	24
Sikkerhetsforskrifter.....	25
Inspeksjon	25
Periodisk inspeksjon.....	25
Beskrivelse	26
Etac Molift RgoSling Toilet LowBack	26
Etac Molift RgoSling Toilet HighBack	26
Vaskeanvisning	26
Applisering av seil.....	28
Løfting.....	29
Senke brukeren til sittende stilling	29
Seil tilpasning og kontrollpunkter	30
Fjerning av seil, sittende.....	31
Kombinasjonsliste	32
Seilguide	32
Feilsøking.....	33

Test og Garanti

CE Dette produktet er CE merket

Etac Molift seil er testet av akkrediterte test institutt og tilfredsstiller standarder I Medical Devices Directive for Class 1 Products MDR (EU) 2017/745 . Seilene oppfylder kravene spesifisert i EN ISO 10535 standarden.

Garanti: 2 år for material og produksjonsfeil ved korrekt bruk.

Besøk www.molift.com for flere detaljer om Etac Molift sitt seil og løfter sortiment

Generelt

Takk for at du valgte et seil fra Molift by Etac.

Brukermanualen må leses grundig for å unngå skade ved håndtering og bruk av produktet

I denne brukermanualen er "bruker" personen som løftes. "Assistenten" er personen som opererer løfteren.



Dette symbolet brukes i manualen der teksten tilsier at det er nødvendig med varsomhet med tanke på brukeren eller assistentens sikkerhet.

Etac forbedrer kontinuerlig produktene, derfor reserverer vi oss retten til å modifisere produktene uten forvarsel.



Besøk www.molift.com for mer informasjon, tips og råd og oppdaterte dokumenter

Vi kan ikke holdes ansvarlig for trykkfeil eller utelatelser

Sikkerhetsforskrifter



Manualen for både løfter og seil må leses nøye før bruk for å unngå skade ved håndtering og bruk av produktet

måned. Hvis seilet vaskes mer enn normalt kan det være nødvendig hyppigere inspeksjoner. See periodisk inspeksjon skjema på www.molift.com

Det er viktig at seilet har blitt testet individuelt med bruker og for den tiltenkte forflytningssituasjonen. Gjør en vurdering om det er nødvendig med en eller flere assistenter.

Planlegg løfteoperasjonen på forhånd for å forsikre at den kan gjennomføres så behagelig og sikkert som mulig. Husk å arbeide ergonomisk.

Vurder risikoen og ta notater. Assistenten er ansvarlig for sikkerheten til brukeren.



Aldri løft brukeren høyere enn nødvendig for å gjennomføre overflytningen. Aldri la brukeren være uten tilsyn i en løftesituasjon



Alltid kontroller:

- At brukeren har nødvendig funksjonsevne for det valgte seilet.
- Modell, størrelse og material passer.
- Seilet passer for løfteren/opphenget som skal brukes.
- Det er viktig å sjekke at løkker er korrekt festet til krok på opphenget før brukeren løftes.
- Hjulene på rullestol eller seng må være låst når det er nødvendig ved overflytning.

Inspeksjon

Seilet må inspiseres regelmessig, helst før hver gang det brukes, men spesielt etter vask.

- Sjekk at det ikke er noen slitasje eller skader på sømmer, stoff, stropper løkker.



Aldri bruk skadede eller slitte seil fordi seilet kan ryke og det kan føre til personskade. Destruer og kast alle skadede og gamle seil.



Seilet må ikke oppbevares i direkte sollys.

Periodisk inspeksjon

Periodisk Inspeksjon må utføres minst hver 6.

Beskrivelse

Etac Molift tilbyr et bredt sortiment med seil for forskjellige typer forflytninger. Etac Molift RgoSling er designet for å gi jevn belastning og en så komfortabelt som mulig forflytning.

Seilet har styrehåndtak for å gjøre det enklere å hjelpe brukeren over i riktig stilling og skal kun brukes når brukeren er løftet.

Etac Molift RgoSling er utviklet for bruk med 4-punkts oppheng, men seilet fungerer også med 2-punkts oppheng. Se kombinasjonslisten for riktig kombinasjonsmuligheter for seil og oppheng.

Molift RgoSling Toilet er tilgjengelig i størrelse XXS – XXL i polstret polyester.

Etac Molift RgoSling Toilet LowBack

har lav rygg, delte benstøtter og stor åpning. Seilet kan brukes til forflytninger fra sittende til sittende stilling.

Etac Molift RgoSling Toilet HighBack

har høy rygg, delte benstøtter og medium åpning. Seilet har hodestøtte. Seilet kan brukes til forflytning fra sittende til sittende stilling.

RgoSling Toilet Lowback og RgoSling Toilet Highback er ikke egnet for personer med liten muskeltonus. Det er fare for at brukere med liten muskeltonus kan falle ut av seilet fordi det har stor åpning.

Produktet har en forventet levetid på 1 til 5 år ved normal bruk. Forventet levetid varierer avhengig av bruksmengde, materialer, hvor stor last og hvor ofte seilet vaskes.

A1. Produktmerkelapp

A2. (01) EAN-kode

xxxxxxxxxxxxxxxx

(21) Serienummer

xxxxxxx

A3. QR-kode

A4. Merkelapp: Periodisk inspeksjon

A5. Merkelapp: Brukernavn

A6. Øvre løftestropp

A7. Magebelte

A8. Polstring

A9. Styrehåndtak side

A10. Styrehåndtak rygg

A11. Hodestøtte justering

A12. Benstøtte

A13. Appliseringslomme ben

A14. Nedre løftestropp

A15. Hodestøtte

A16. Symbol: Les brukermanual

A17. Symbol: Maks brukervekt

A18. Symbol: Denne side av produktet er vendt opp og utover

A19. Symbol: Brett ut for mer informasjon

Vaskeanvisninger

Les vaskeanvisninger på produktet.

1. Seil som kan vaskes i vann kan vaskes på temperatur fra 60 til 85° C.



Vask på høyere temperaturer gjør at stoffet slites ut raskere.

2. Tørketrommel, maks 45° C.

Kan autoklaves på 85° C i 30 minutter

3. Skal ikke renses kjemisk.

4. Skal ikke blekes.

5. Skal ikke strykes.

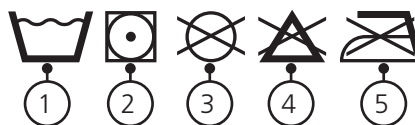

Symboler:



Produsent



Produksjonsdato.
ÅÅÅÅ-MM-DD
(år/måned/DD)



Denne siden opp,
denne siden ut



max 255 kg max 560 lbs Maks. brukervekt (SWL)



CE-merket



Medisinsk utstyr



Se bruksanvisningen

A

RgoSling Toilet LowBack

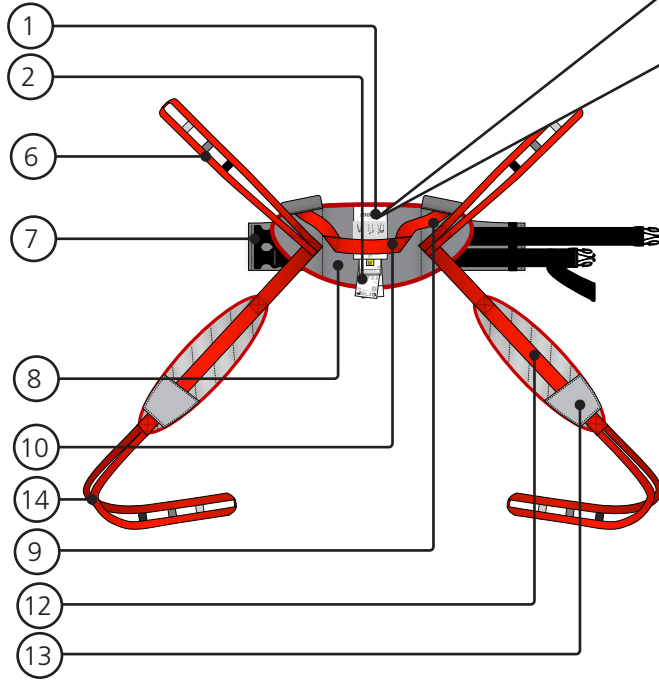

RgoSling Toilet HighBack

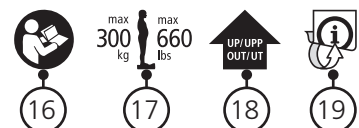
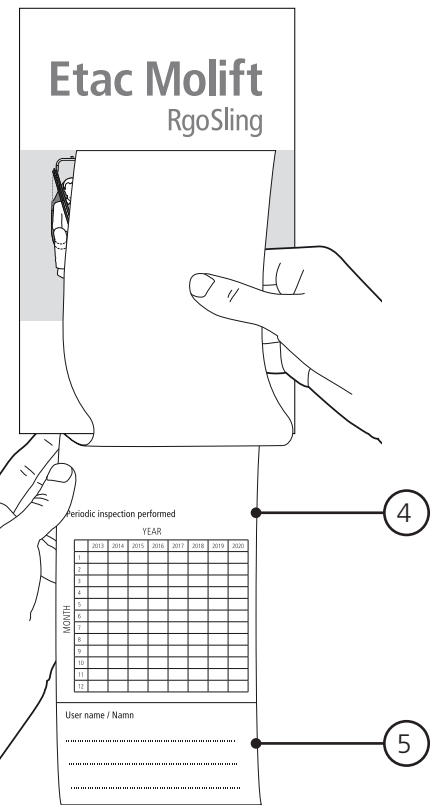
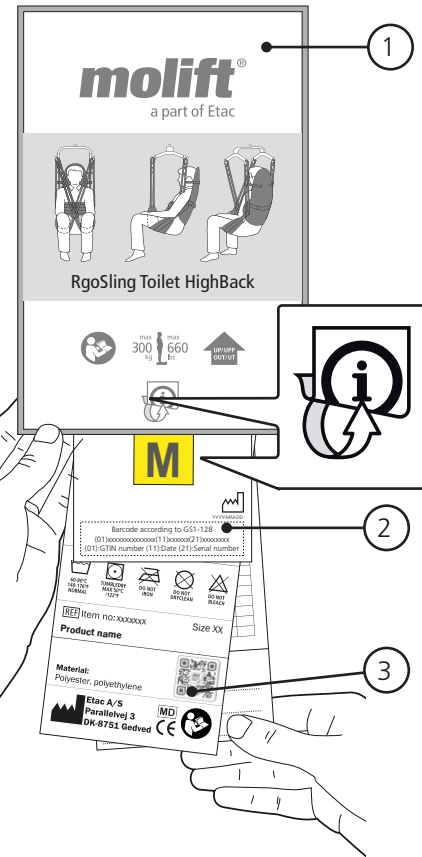
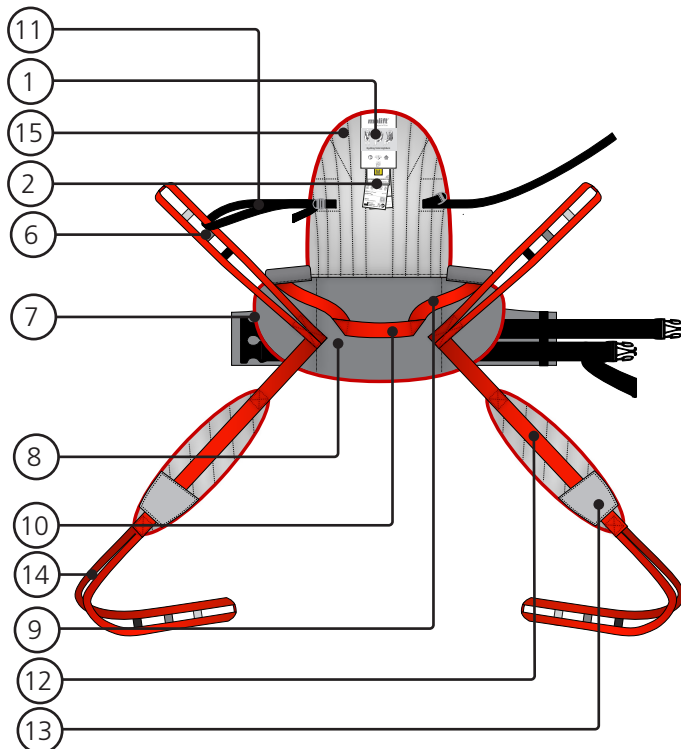

B

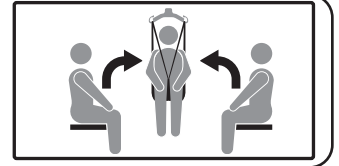

Applisering av seil

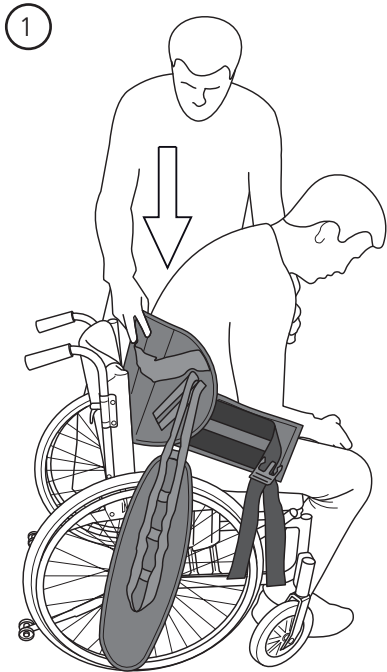

B1. Forbered brukeren ved å kneppe opp bukser. Hold seilet med en hånd og bruk den andre til å støtte brukeren. Plasser seilet ned bak brukerens rygg omtrent i høyde med midjen.

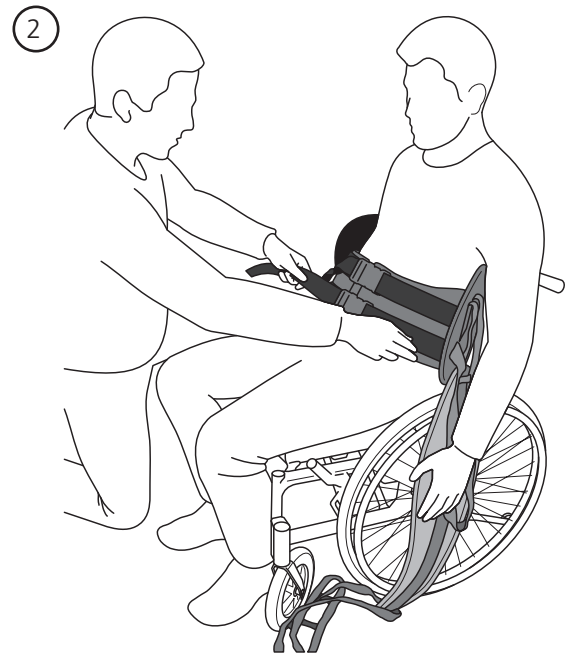

B2. Koble til magebeltet og stram til. Sør for at brukeren bukser er tilgjengelige.

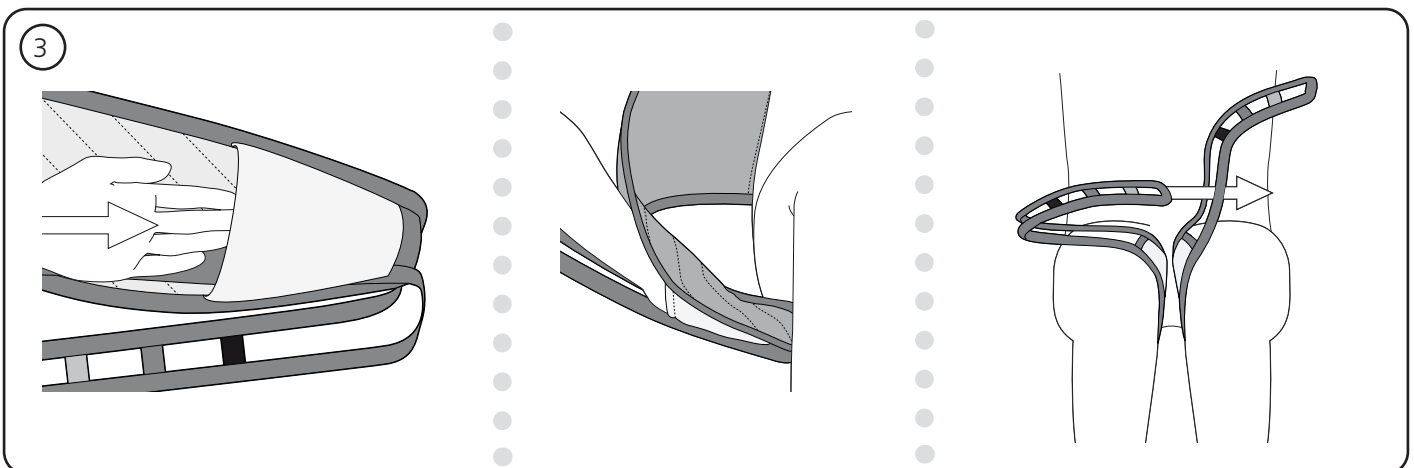

B3. Plasser benstøttene under brukeren lår. Lommen på benstøttene forenkler appliseringen. Kryss benstøttene ved å trekke en av benstroppene gjennom den andre.

Løfting

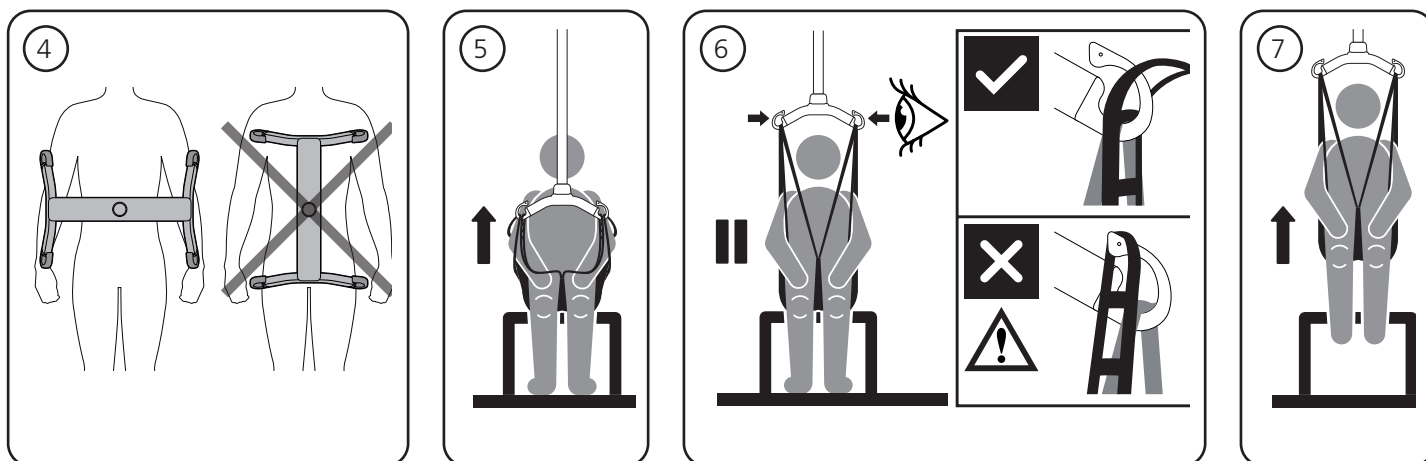

B4. Opphenget må alltid plasseres på tvers av bruker for å unngå at brukeren faller ut av seilet.

B5. Koble løkkene til opphengets kroker.

B6. Løft til stroppene strammes uten at bruker løftes. Sjekk at seilet er riktig applisert på

bruker og at løkkene er skikkelig festet til opphengets kroker.

B7. Løft ikke brukeren høyere en nødvendig. Huska at hjul på mobile løfter IKKE skal være låst.

Senke brukeren til sittende stilling

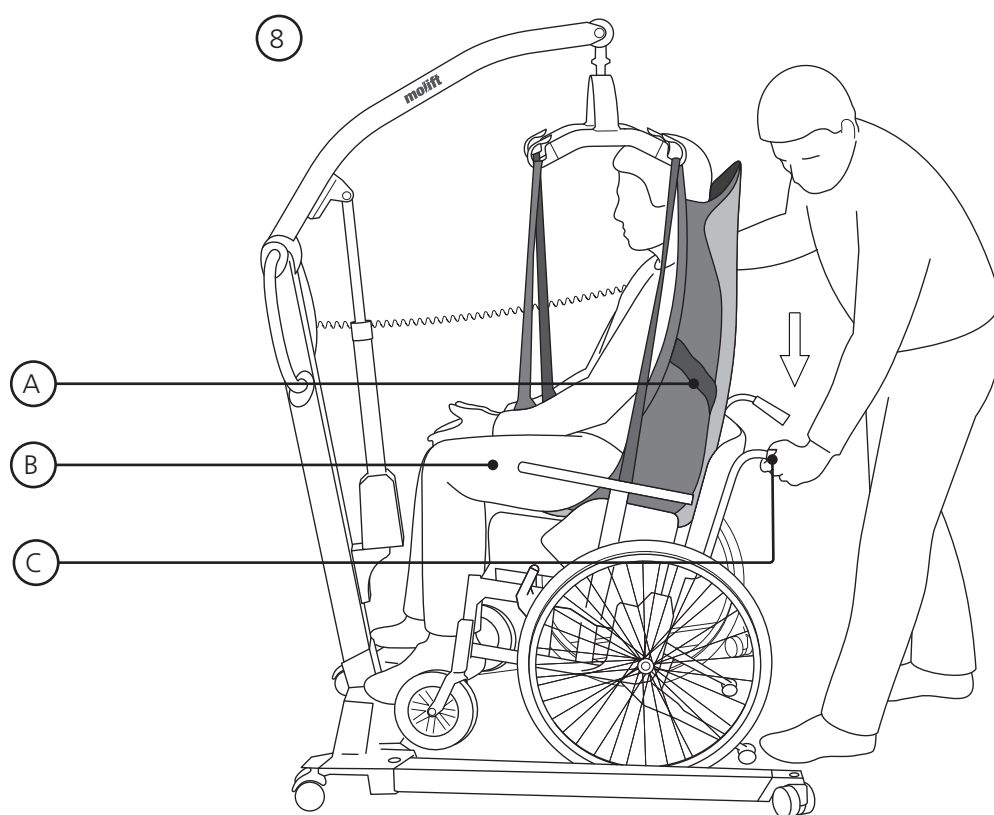

B8. Når brukeren forlyttes til sittende kan følgende teknikker brukes for å senke brukeren så langt bak i setet som mulig:

A. Styr brukeren med styrehåndtakene på seilet
B. Skyv forsiktig på brukerens knær
C. Tipp setet bakover

C

Seil tilpasning og kontrollpunkter

RgoSling Toilet LowBack

- C1. Sørg for at opphenget ikke er i nærheten av brukerens ansikt
- C2. Magebelte er festet og strammet til
- C3. Kryss benstøttene
- C4. Benstøttene er plassert riktig
- C5. Ryggstøtten er plassert i riktig høyde

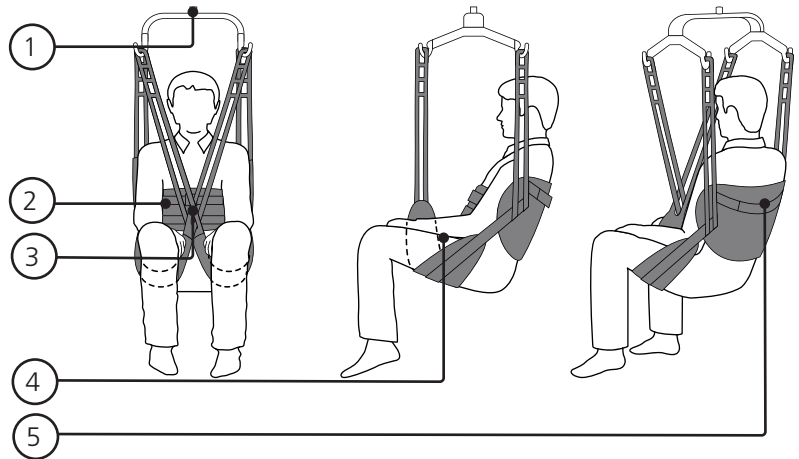

RgoSling Toilet High-

- C6. Sørg for at opphenget ikke er i nærheten av brukerens ansikt
- C7. Magebelte er festet og strammet til
- C8. Kryss benstøttene
- C9. Benstøttene er plassert riktig
- C10. Ryggstøtten er plassert i riktig høyde
- C11. Hodestøtte justering

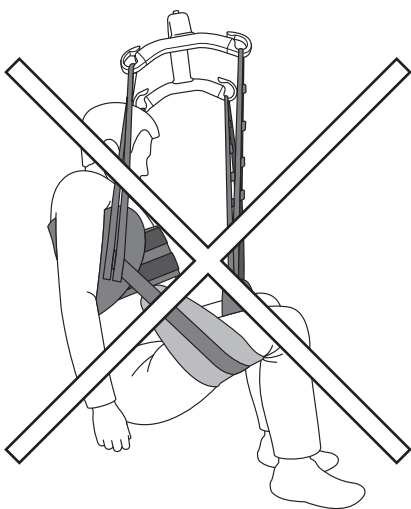
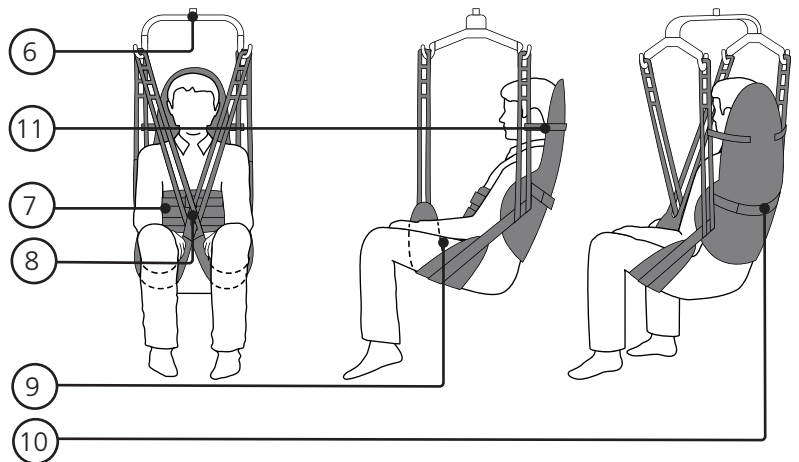

C12. Feilaktig plassering av seilet. Ryggstøtten er plassert for høyt og benstøtter for langt frem. Situasjonen kan også oppstå hvis brukeren har for liten muskeltonus.

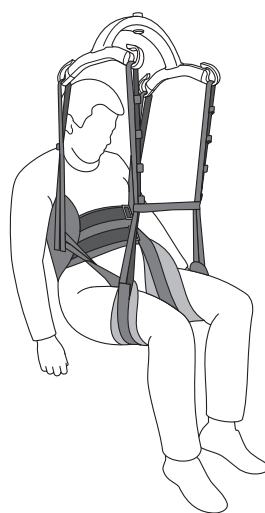

C13. Alternativ benstøt-teplassering ved bruk av extension loops.

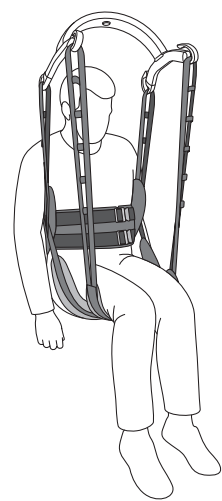

C14. Alternativ benstøt-teplassering med begge benstøtter under begge ben

D

Fjerning av seil, sittende

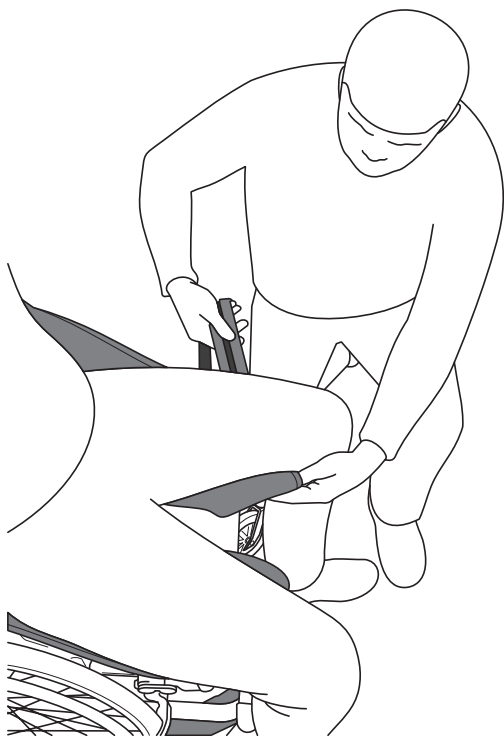



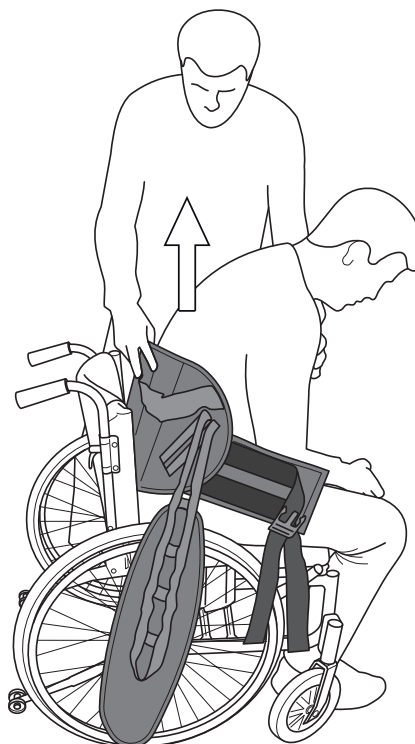







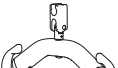
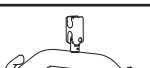
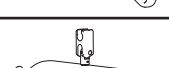
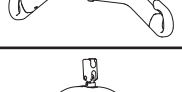

D1. Fjern benstøtten ved å folde det under brukers lår og deretter trekk det ut.

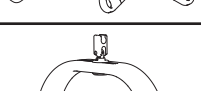

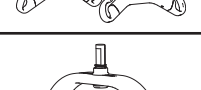
D2. Stå ved siden av stolen. Stått med en hånd mens brukeren lenes forover. Trekk frem seilet med den andre hånden, og len brukeren tilbake i stolen. Hvis seilet trekkes opp for raskt, kan brukeren falle hodestups forover og bli skadet. Alltid hold en hånd rundt brukeren.

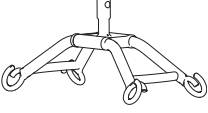
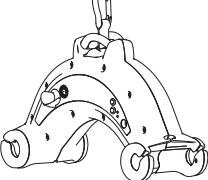
Kombinasjonsliste

Oppheng		RgoSling Toilet Lowback / RgoSling Toilet Highback		
		XXS - S	S - L	L - XXL
Mover 180				
	2-pt Small	✓		
	2-pt Medium	✓	✓	
	2-pt Large		✓	
	4-pt Medium	✓	✓	✓
	4-pt Large		✓	✓
Mover 205				
	2-pt Small	✓		
	2-pt Medium	✓	✓	
	2-pt Large		✓	
	4-pt Medium	✓	✓	✓
	4-pt Large		✓	✓
Mover 300				
	4-pt Medium	✓	✓	✓
	4-pt Large		✓	✓
Partner 255				
	4-pt Medium	✓	✓	✓
	4-pt Large		✓	✓

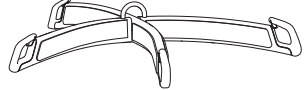
Oppheng		RgoSling Toilet Lowback / RgoSling Toilet Highback		
		XXS - XS	S - L	XL - XXL
Smart				
	4-pt Medium	✓	✓	✓
Nomad				
	4-pt Medium	✓	✓	✓
Nova				
	2-pt Small	✓		
	2-pt Medium	✓	✓	
	2-pt Large		✓	
	4-pt Medium		✓	✓
	4-pt Large			✓

Seilguide

Valg av størrelse varierer avhengig av vekt, kroppsfunksjon og omkrets/størrelse på brukeren. SWL (Maks last) er 300.

Størrelse	Vekt (Kg)
XXL	230-300
XL	160-240
L	90-160
M	45-95
S	25-50
XS	17-25
XXS	12-17

Feilsøking

Symptom	Årsak/løsning
Seilet passer ikke brukeren.	Feil størrelse på seilet. Prøv en annen størrelse.
	Seilet er for lite når benstøttene ikke rekker halvveis rundt låret og opphenget er for nærme brukerens ansikt. Prøv en annen størrelse.
	Seilet er ikke plassert riktig. Sørg for å skyve seilet langt nok ned bak ryggen når det appliseres.
Stroppene løfter ikke samtidig.	Hvis løftestroppene løfter ujevnt så kan det føre til at seilet gli opp langs ryggen og brukeren kan gli ut gjennom åpningen av seilet. Sørg for at benstøttene er plassert korrekt.
Brukeren glir ut/gjennom seilet.	Seilet er ikke koblet riktig til opphenget i henhold til individuell tilpasning.
	Brukeren har for glatte klær. Fjern eller bytt noen av brukerens plagg.

Dansk vejledning

Indhold

Generelt.....	34
Test og garanti	34
Sikkerhedsforanstaltninger.....	35
Inspektion	35
Periodisk inspektion	35
Beskrivelse	36
Etac Molift RgoSling Toilet LowBack	36
Etac Molift RgoSling Toilet HighBack	36
Pleje/vask.....	36
Anvendelse af sejlet.....	38
Løftning.....	39
Nedsænkning til siddende stilling	39
Sejjustering og kontrolpunkter	40
Fjernelse af sejl	41
Kombinationsoversigt	42
Valg af sejl	42
Fejlfinding	43

Test og garanti

CE Dette produkt er CE-mærket.

Etac Molift-sejl er testet af godkendte testinstitutioner og overholder de standarder, der er angivet i Direktivet for medicinsk udstyr for klasse 1-produkter MDR (EU) 2017/745. Sejlene opfylder de krav, der er angivet i standarden EN ISO 10535.

Garanti: To år på materiale- og fremstillingsfejl, under forudsætning af korrekt brug.

Se www.molift.com for yderligere oplysninger om Etac Molifts udvalg af sejl og personløftere.

Generelt

Tak, fordi du har valgt et Molift-sejl fra Etac

Læs vejledningen grundigt for at undgå skader under håndtering og brug af produktet.

I vejledningen er Brugeren den person, der bliver løftet. Hjælperen er den person, der betjener sejlet.



Dette symbol vises i vejledningen sammen med tekst. Det angiver behov for forsigtighed, når der kan være risiko for brugerens eller hjælperens sikkerhed.

Etac forbedrer løbende sine produkter. Vi forbeholder os derfor ret til at ændre produkterne uden forudgående meddelelse.



Besøg www.molift.com for at få flere oplysninger, tips og eventuelle dokumentationsopdateringer.

Vi frasiger os ansvaret for eventuelle trykfejl eller udeladelser.

Sikkerhedsforanstaltninger



Læs vejledningen til både personløfter og sejl grundigt før brug for at undgå skader under håndtering og brug af produktet.

Der skal som minimum udføres periodisk inspektion hver sjette måned. Det kan være nødvendigt med hyppigere inspektion, hvis sejlet anvendes eller vaskes oftere end det normale. Se formular for periodisk inspektion på www.molift.com.

Det er vigtigt, at sejlet er blevet afprøvet sammen med den enkelte bruger og anvendes til den tilsigtede løftesituation. Der skal tages beslutning om, hvorvidt det er nødvendigt med kun en eller flere hjælpere.

Planlæg løfteoperationen på forhånd for at sikre, at den foregår så sikkert og ubesværet som muligt. Husk at arbejde ergonomisk korrekt.

Vurdér risiciene, og tag notater. Som omsorgsperson er du ansvarlig for brugerens sikkerhed.



Løft aldrig en bruger højere fra udgangspunktet, end det, der er nødvendigt for at kunne udføre løftet. Efterlad aldrig en bruger uden opsyn i en løftesituation.



Kontrollér altid:

- om brugeren har de nødvendige evner i forhold til det aktuelle sejl.
- At model, størrelse og materiale er hensigtsmæssige.
- At sejlet egner sig til det løft, der skal udføres.
- Det er vigtigt at kontrollere, at stropløkkerne er korrekt fastgjort i løftekrogene, før brugeren løftes.
- Sørg for, at hjulene på kørestolen, sengen eller lejet er låst, når det er nødvendigt i forbindelse med forflytningsprocessen.

Inspektion

Sejlet skal inspiceres regelmæssigt, helst før hver enkelt løfteoperation, men specielt efter det er blevet vasket.

- Kontrollér sejlet for at sikre dig, at der ikke er slitage eller skader på sømme, stof, stropper og løkker.



Anvend aldrig et fejlbehæftet eller beskadiget sejl, da det kan gå i stykker og forårsage personskade. Kassér og bortskaf beskadigede og gamle sejle.



Sejlet må ikke opbevares i direkte sollys.

Periodisk inspektion

Beskrivelse

Etac Molift leverer et bredt udvalg af sejl til forskellige forflytningstyper. Etac Molift RgoSling er konstrueret til at fordele vægt og belastning jævnt, så sejlet er så komfortabelt som muligt.

Sejlet har et styregreb, som gør det nemmere at placere brugeren i den korrekte siddestilling. Grebet anvendes kun under løft.

Etac Molift RgoSling er konstrueret til at blive kombineret med et 4-punkts løfteophæng, men sejlet kan også benyttes med et 2-punkts løfteophæng. For korrekt kombination af sejl og løfteophæng, se kombinationsoversigten.

Molift RgoSling Toilet findes i størrelserne XXS-XXL, i polstret polyester.

Etac Molift RgoSling Toilet LowBack

Etac Molift RgoSling Toilet LowBack har lav ryg, delt benstøtte og en bred åbning. Sejlet kan anvendes til løft til og fra siddende stilling.

Etac Molift RgoSling Toilet HighBack

Etac Molift RgoSling Toilet HighBack har høj ryg, delt benstøtte og en medium åbning. Sejlet har hovedstøtte. Sejlet kan anvendes til løft til og fra siddende stilling.

RgoSling Toilet LowBack og RgoSling Toilet HighBack kan ikke anvendes til personer med lav muskeltonus. Der vil være en høj risiko for, at en bruger med lav muskeltonus glider ud af sejlet, fordi det har en bred åbning.

Produktet har en forventet levetid på 1-5 år ved normal brug. Levetiden for produktet varierer, afhængigt af brugshyppighed, materialer, belastninger og hvor ofte, det vaskes.

A1. Produktmærkat

A2. (01) EAN-kode

xxxxxxxxxxxxxx

(21) Serienummer

xxxxxxx

A3. QR-kode

A4. Mærkat: Periodisk inspektion

A5. Mærkat: Brugernavn

A6. Øverste stropløkke

A7. Mavebælte

A8. Polstring

A9. Styregreb, side

A10. Styregreb, ryg

A11. Hovedstøttejustering

A12. Benstøtte

A13. Styrelomme, ben

A14. Nederste stropløkker

A15. Hovedstøtte

A16. Symbol: Læs vejledningen inden brug.

A17. Symbol: Maks. brugervægt

A18. Symbol: Denne side af produktet vendes opad og udad

A19. Symbol: Fold ud for flere oplysninger

Pleje/vask

Læs instruktionerne for pleje/vask på produktet.

1. Vaskbare sejl kan vaskes i vand ved temperaturer mellem 60 og 85 °C.

 Vask ved højere temperaturer vil bevirke, at materialet slides hurtigere.

2. Kan tørretumbles ved maks. 45 °C.

Kan autoklaveres ved 85 °C i 30 minutter.

3. Ingen kemisk rens.

4. Ingen blegning.

5. Ingen strygning.

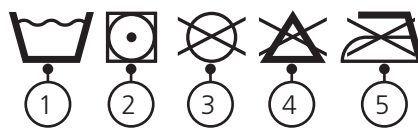

Symboler:



Producent



Produktionsdato.
ÅÅÅÅ-MM-DD
(år/måned/dag)



CE-mærket



Se brugervejledning



Denne side op,
denne side er ydersiden



Maks. brugervægt
(sikker arbejdsbelastning)



Medicinsk udstyr

EN
SV
NO
DA
FI
DE
NL
FR
IT
ES

A

RgoSling Toilet LowBack

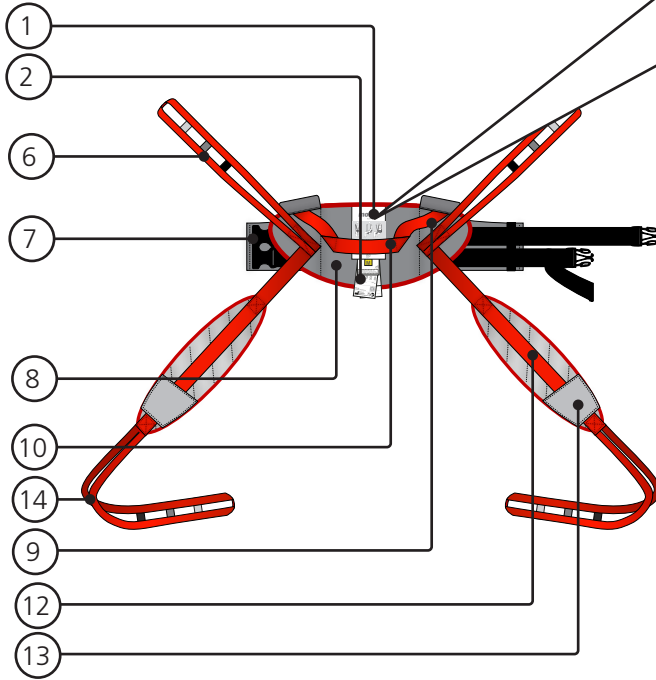

RgoSling Toilet HighBack

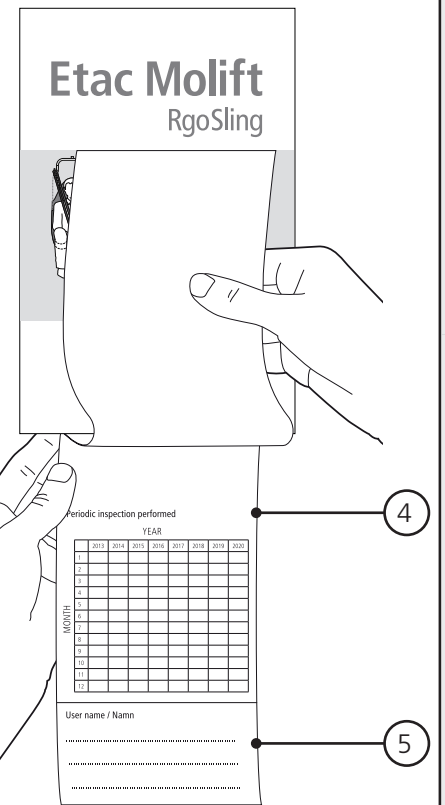
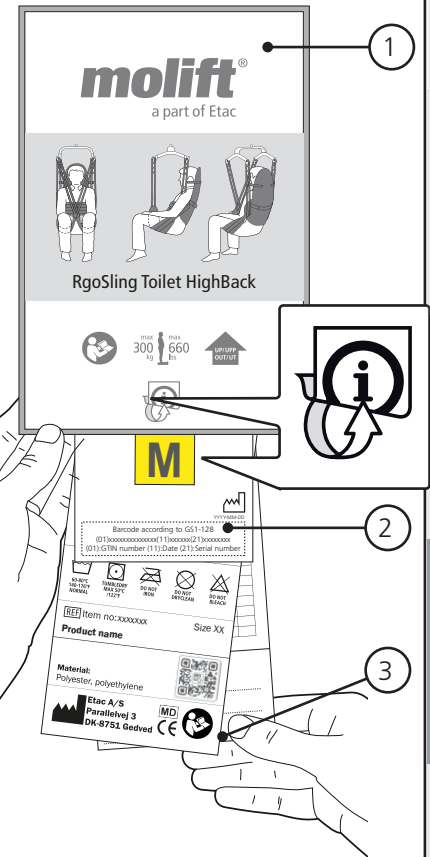
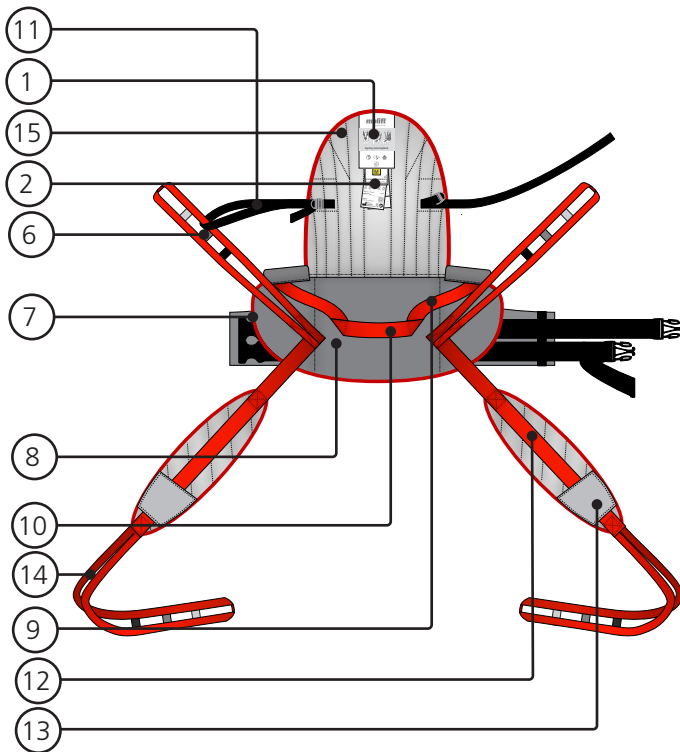

B

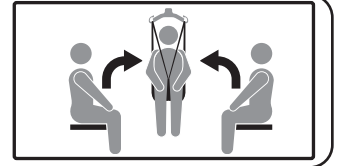

Anvendelse af sejlet

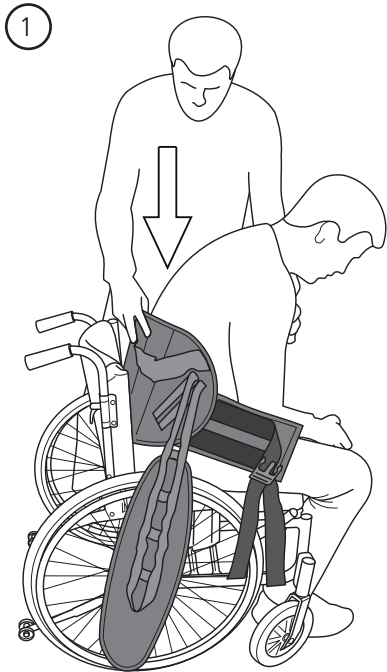

B1. Forbered brugeren ved at åbne vedkommendes bukser. Hold sejlet med den ene hånd, og brug den anden til at støtte brugeren. Lad sejlet glide ned bag brugerens ryg. Placer sejlet cirka i taljehøjde bagpå..

B2. Fastgør mavebæltet, og stram det. Sørg for, at der er adgang til bukserne.

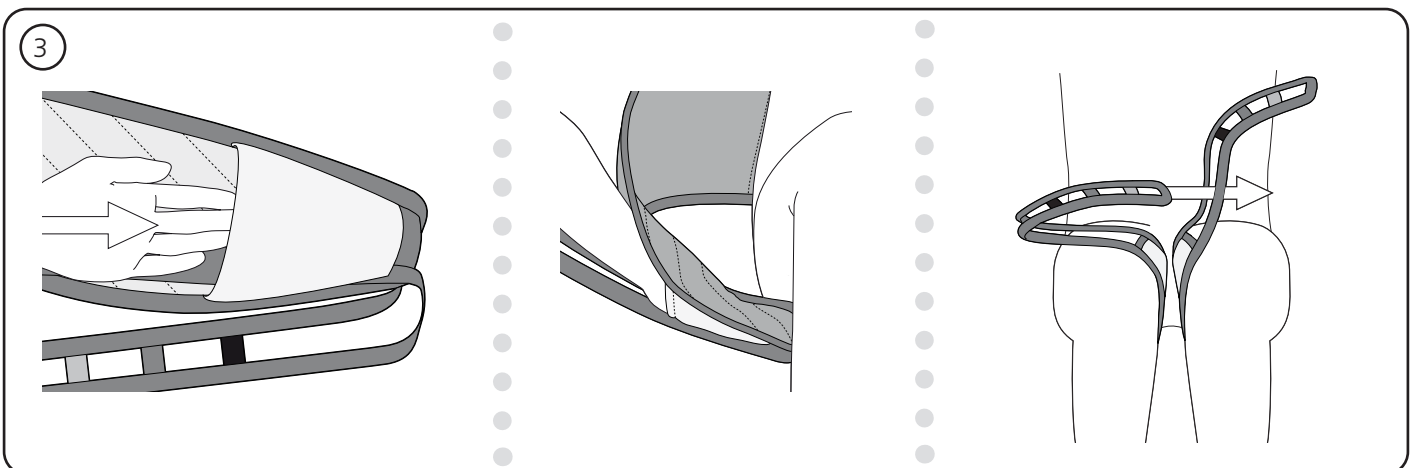

B3. Anbring benstøtterne under brugerens lår. Lommen yderst på benstøtten gør det nemmere at placere støtterne. Kryds benløkkerne ved at trække en af løkkerne gennem den anden.

Løftning

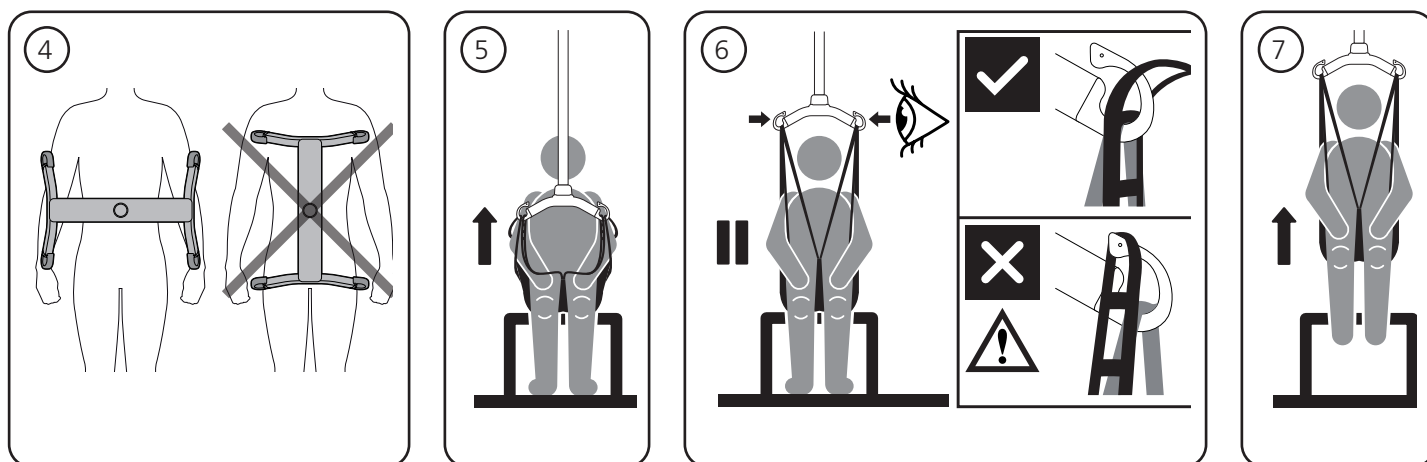

B4. Løfteophænget skal altid anbringes på tværs af brugeren for at forhindre, at brugeren ved et uheld glider ud af sejlet.

B5. Hæng sejlet i krogene på løfteophænget.

B6. Stræk sejlstropperne uden at løfte brugeren. Sørg for, at sejlet er placeret korrekt omkring

brugeren, og at stropløkkerne er placeret korrekt i krogene på løfteophænget.

B7. Løft ikke brugeren højere op end nødvendigt. Husk, at hjulene på en mobil personløfter IKKE må låses.

Nedsænkning til siddende stilling

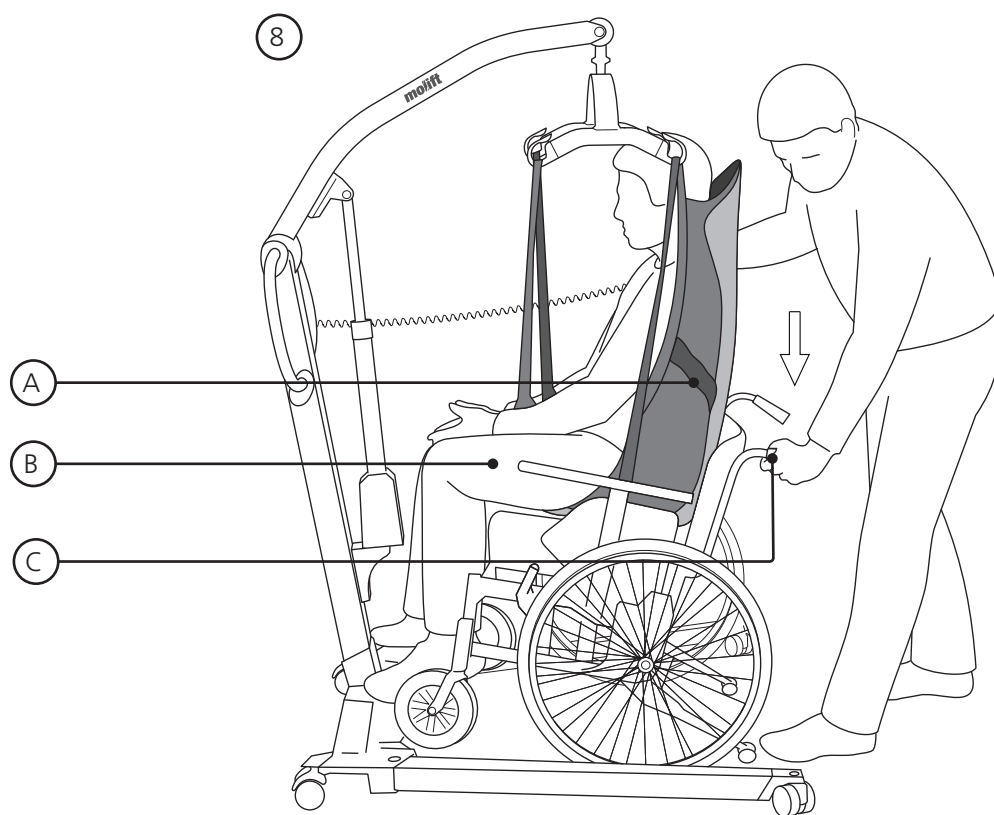

B8. Når brugeren overføres til siddende stilling kan følgende teknikker anvendes, når brugeren skal sænkes så langt tilbage i sædet som muligt.

A. Placér brugeren ved hjælp af styregrebet
B. Skub forsigtigt på brugers knæ
C. Tip sædet tilbage

C

Sejjustering og kontrolpunkter

RgoSling Toilet LowBack

- C1. Sørg for, at ophænget er på sikker afstand af brugerens ansigt
- C2. Mavebæltet skal være låst og strammet
- C3. Ophængsløkkerne skal være krydset
- C4. Benstøtten skal være korrekt placeret
- C5. Rygstøtten skal være anbragt i korrekt højde

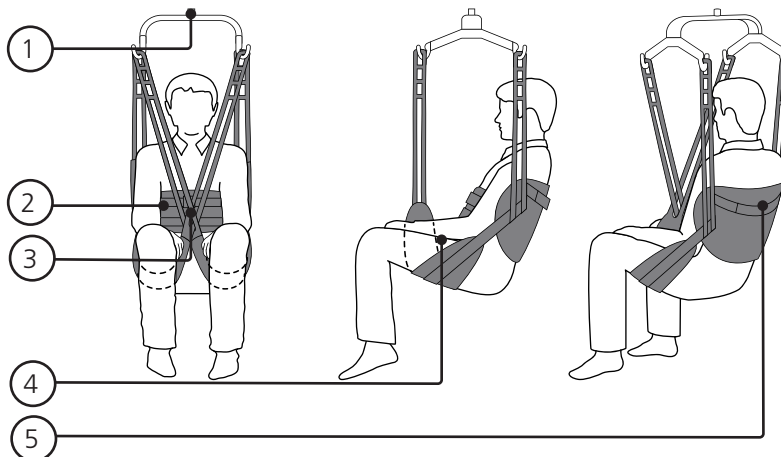

RgoSling Toilet HighBack

- C6. Sørg for, at ophænget er på sikker afstand af brugerens ansigt
- C7. Mavebæltet skal være låst og strammet
- C8. Ophængsløkkerne skal være krydset
- C9. Benstøtten skal være korrekt placeret
- C10. Rygstøtten skal være anbragt i korrekt højde
- C11. Hovedstøttejustering

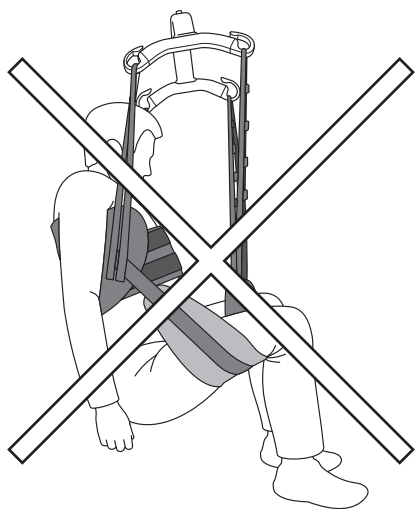
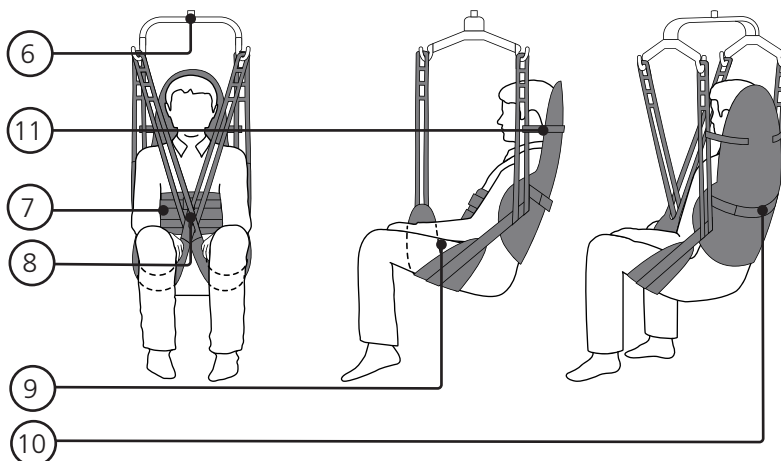

- C12. Forkert placering af sejlet. Rygstykket er anbragt for højt, og benstøtten er for langt fremme. Situationen kan også opstå, hvis brugeren ikke har tilstrækkelig muskeltonus.

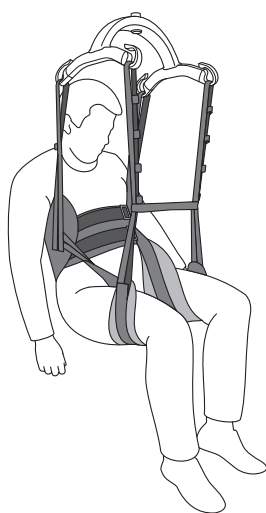

- C13. Alternativ benstøtteplacering, hvor der bruges ekstra forlængerløgner.

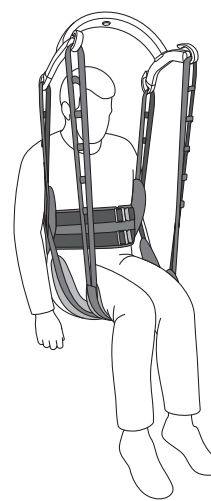

- C14. Alternativ benstøtteplacering, med benstøtter under begge ben.

D

Fjernelse af sejl

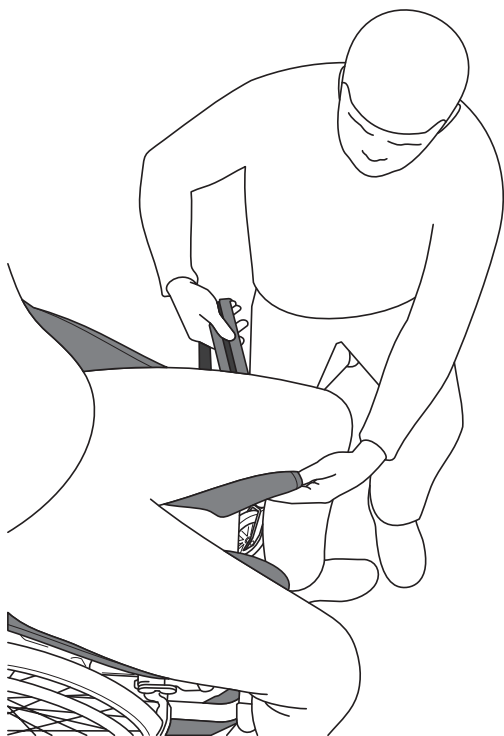



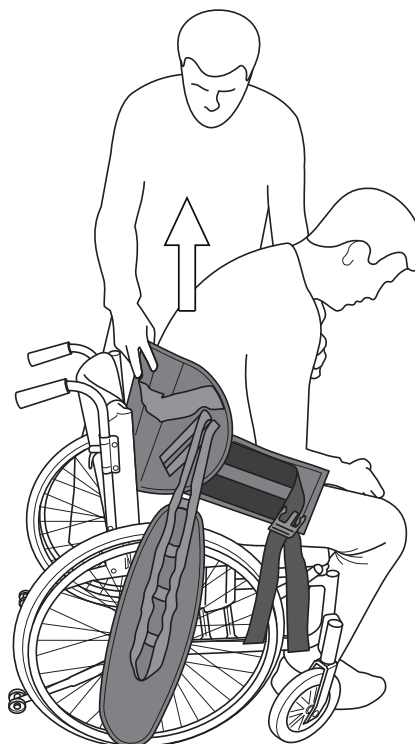









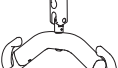
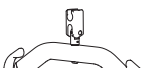
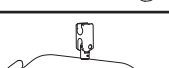
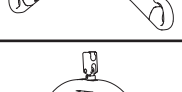

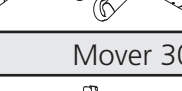

D1. Fjern benstøtten ved at folde den ind under selve sejlet og brugerens lår, og træk ud.

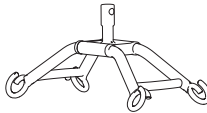
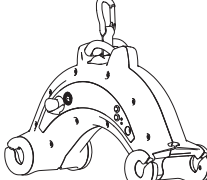

D2. Stå ved siden af stolen, og læn brugeren fremad, mens du støtter med den ene hånd. Træk sejlet væk med den anden hånd, og læn brugeren tilbage i stolen. Hvis du trækker hårdt op i sejlet, kan brugeren falde fremad og komme til skade. Hold altid omkring brugeren med den ene hånd.

Kombinationsoversigt

Suspension		RgoSling Toilet Lowback / RgoSling Toilet Highback		
		XXS - S	S - L	L - XXL
Mover 180				
	2-pt Small	✓		
	2-pt Medium	✓	✓	
	2-pt Large		✓	
	4-pt Medium	✓	✓	✓
	4-pt Large		✓	✓
Mover 205				
	2-pt Small	✓		
	2-pt Medium	✓	✓	
	2-pt Large		✓	
	4-pt Medium	✓	✓	✓
	4-pt Large		✓	✓
Mover 300				
	4-pt Medium	✓	✓	✓
	4-pt Large		✓	✓
Partner 255				
	4-pt Medium	✓	✓	✓
	4-pt Large		✓	✓

Suspension		RgoSling Toilet Lowback / RgoSling Toilet Highback		
		XXS - XS	S - L	XL - XXL
Smart				
	4-pt Medium	✓	✓	✓
Nomad				
	4-pt Medium	✓	✓	✓
Nova				
	2-pt Small	✓		
	2-pt Medium	✓	✓	
	2-pt Large		✓	
	4-pt Medium		✓	✓
	4-pt Large			✓

Valg af sejl

Den størrelse, du skal vælge, afhænger af brugerens vægt, funktion og kropstørrelse/-omkreds. Sikker arbejdsbelastning (SWL, Safe Working Load) er 300 kg

Size	Weight (Kg)
XXL	230-300
XL	160-240
L	90-160
M	45-95
S	25-50
XS	17-25
XXS	12-17

Fejlfinding

Symptom	Mulig årsag/udbedring
Sejlet passer ikke til brugeren.	Forkert sejlstørrelse. Prøv med en anden størrelse.
	Sejlet er for lille, når benstøtterne ikke kan nå halvvejs rundt om inderlåret, og ophænget befinder sig for tæt på brugerens ansigt. Prøv med en anden størrelse.
	Sejlet er ikke korrekt placeret. Træk sejlet tilstrækkeligt langt ned bagtil, når du placerer det.
Alle stropperne løfter ikke samtidigt.	Hvis sejlstropperne løfter ujævnt, kan sejlet glide op bagpå, hvilket kan medføre, at brugeren glider ned i åbningen i sejlet. Sørg for, at benstøtterne er korrekt placeret på lårene.
Brugeren glider gennem eller ud af sejlet.	Sejlet er ikke forbundet korrekt i forhold til individuelle forskrifter.
	Brugeren er iført for glat tøj. Skift eller fjern noget af tøjet.

EN

SV

NO

DA

DE

NL

FR

ES

Suomenkielinen käyttöopas

Sisältö

Yleistä.....	44
Testaus ja takuu	44
Turvallisuusohjeet	45
Tarkastus	45
Määräaikaistarkastus.....	45
Kuvaus.....	46
Etac Molift RgoSling Toilet LowBack	46
Etac Molift RgoSling Toilet HighBack	46
Huolto/pesu.....	46
Nostoliinan käyttö	48
Istumahissit	49
Laskeminen istuma-asentoon.....	49
Nostoliinan säätäminen ja tarkastettavat kohdat	50
Nostoliinan poistaminen	51
Yhdistelmätaulukko	52
Nostoliinan koko-opas.....	52
Ohjeita ongelmatilanteisiin.....	53

Testaus ja takuu

CE Tämä tuote on CE-merkitty.

Etac Molift -nostoliinat on testattu hyväksytyjen testauslaitosten toimesta, ja ne ovat luokan 1 lääkinällisiä laitteita koskevan direktiivin MDR (EU) 2017/745 mukaisia. Nostoliinat ovat standardin EN ISO 10535 vaatimusten mukaisia.

Takuu: Kaksi vuotta materiaali- ja valmistusvirheille asianmukaisessa käytössä.

Tutustu Etac Molift -nostoliinoiden ja -nostolaitteiden tuotevalikoimaan osoitteessa www.molift.com.

Yleistä

Kiitos, että valitsit Etacin Molift-nostoliinan.

Lue käyttöopas huolellisesti, jotta vältetään vauriot tuotteen käsittelyn ja käytön yhteydessä.

Tässä käyttöoppaassa käyttäjällä tarkoitetaan nostettavaa henkilöä.

Avustaja on nostoliinaa ohjaava henkilö.



Tämä kuvake näkyy käyttöoppaassa yhdessä tekstin kanssa. Se osoittaa, että on toimittava varovasti, koska muutoin käyttäjän tai avustajan turvallisuus voi vaarantua.

Etac tekee jatkuvasti parannuksia tuotteisiinsa. Pidätämme siksi oikeuden muuttaa tuotteita ilman aiempaa ilmoitusta.



Osoitteesta www.molift.com saat lisätietoja, ohjeita ja ajantasaisimmat dokumentit.

Emme vastaa painovirheistä tai puuttuvista tiedoista.

Turvallisuusohjeet

sessä käytettävä lomake löytyy osoitteesta www.molift.com.

Huomaa



Lue sekä nostolaitteen että nostoliinan käyttöopas huolellisesti ennen käyttöä vaurioiden välttämiseksi tuotteen käsittelyn ja käytön yhteydessä.

Nostoliina tulee testata yksittäistä käyttäjää ja nostotilanteen käyttötarkoitusta varten. Varmista, tarvitaanko nostotilanteessa yksi avustaja vai useampia avustajia.

Suunnittele nostotoimenpide etukäteen, jotta voidaan varmistaa, että nostaminen tapahtuu turvallisesti ja sujuvasti. Työskentele ergonomisesti.

Arvioi riskit ja tee muistiinpanoja. Hoitohenkilöstö on vastuussa käyttäjän turvallisuudesta.



Älä koskaan nosta käyttäjää tarpeettoman korkealle aloituspisteestä noston yhteydessä. Älä koskaan jätä käyttäjää ilman valvontaa nostotilanteessa.



Tarkasta aina seuraavat:

- Kyseinen nostoliina soveltuu käyttäjälle.
- Malli, koko ja materiaali ovat sopivat.
- Nostoliina soveltuu käytettävälle nostolaitteelle/ripustukselle.
- Nostolenkit on kiinnitetty oikein ripustuksen koukkuihin ennen käyttäjän nostamista.
- Pyörätuolin tai sängyn pyörät on tarvittaessa lukittu siirtämisen ajaksi.

Tarkastus

- Nostoliina tulee tarkastaa säännöllisesti, mieluiten ennen jokaista nostotilannetta ja erityisesti aina pesun jälkeen.
- Tarkasta, että saumoissa, kankaassa, hihnoissa ja lenkeissä ei ole kulumia tai vaurioita.



Älä koskaan käytä viallista tai vaurioitunutta nostoliinaa, koska se voi mennä rikki ja aiheuttaa henkilövahinkoja. Hävitä ja poista käytöstä vaurioituneet ja vanhat nostoliinat.



Älä varastoi nostoliinaa suorassa auringonvalossa.

Määräaikaistarkastus

Määräaikaistarkastus tulee tehdä vähintään 6 kuukauden välein. Säännöllisempi tarkastus voi olla tarpeen, jos nostoliinaa käytetään tai pestään normaalia useammin. Säännöllisessä tarkastuk-

Kuvaus

Etac Molift -valikoimasta löytyy nostoliinoja erityyppisiä siirtoja varten. Molift RgoSling on suunniteltu niin, että paino ja paine jakautuvat tasaisesti, jotta tuotetta on mahdollisimman miellyttävä käyttää.

Ohjauslenkin avulla käyttäjä on helppo asettaa asianmukaiseen istuma-asentoon. Ohjauslenkkiä käytetään vain käyttäjää nostettaessa.

Molift RgoSling on suunniteltu yhdistettäväksi 4-pisteripustukseen, mutta nostoliinaa voidaan käyttää myös 2-pisteripustuksen kanssa. Katso oikeat nostoliinojen ja ripustusten yhdistelmät yhdistelmäluettelosta.

Molift RgoSling Toilet -tuotteesta on saatavilla koot XXS–XXL, materiaalina pehmustettu polyesteri.

Etac Molift RgoSling Toilet LowBack

Tuotteessa on matala selkäosa. Jaetussa jalkatuessa on suuri aukko. Nostoliinaa voidaan käyttää nostamiseen istuma-asennosta ja siirtämiseen istuma-asentoon.

Etac Molift RgoSling Toilet HighBack

Tuotteessa on korkea selkäosa. Jaetussa jalkatuessa on keskikokoinen aukko. Nostoliinassa on päätuki. Nostoliinaa voidaan käyttää nostamiseen istuma-asennosta ja siirtämiseen istuma-asentoon.

RgoSling Toilet LowBack ja RgoSling Toilet HighBack eivät sovellu käyttäjille, joilla on alentunut lihasjänteys. Jos käyttäjällä on alentunut lihasjänteys, on vaarana, että henkilö liukuu pois nostoliinasta, koska nostoliinassa on suuri aukko.

Tuotteen arvioitu käyttöikä on 1–5 vuotta normaalissa käytössä. Tuotteen käyttöikä vaihtelee käyttö- ja pesutiheyden, materiaalien sekä kuormituksen mukaan.

- A1. Tuotetarra
- A2. (01) EAN-koodi
xxxxxxxxxxxxxxx
(21) Sarjanumero
xxxxxxx
- A3. QR-koodi
- A4. Merkki: Määräaikaistarkastus
- A5. Merkki: Käyttäjän nimi
- A6. Ylempi nostolenkki
- A7. Lantiovyö
- A8. Pehmuste
- A9. Sivussa oleva ohjauslenkki
- A10. Takana oleva ohjauslenkki
- A11. Päätuen säätö
- A12. Jalkatuki
- A13. Jalkatuessa oleva sovitustasku
- A14. Alempi nostolenkki
- A15. Päätuki
- A16. Kuvake: Lue käyttöopas ennen käyttöä
- A17. Kuvake: Käyttäjän enimmäispaino
- A18. Kuvake: Tämä puoli tuotteesta käännetään ylöspäin ja ulospäin
- A19. Kuvake: Avaa ja lue lisätietoja

Huolto/pesu

Lue tuotteessa olevat huolto-ohjeet..

1. Vesipesun kestävät nostoliinat voidaan pestä 60–85 °C:n lämpötilassa.



Pesu korkeammissa lämpötiloissa kuluttaa materiaalia nopeammin.

2. Rumpukuivaus enintään 45 °C:ssa. Voidaan desinfioida autoklaavissa 85 asteessa 30 minuutin ajan.
3. Ei saa kuivapestä..
4. Ei saa valkaista.
5. Ei saa silittää.

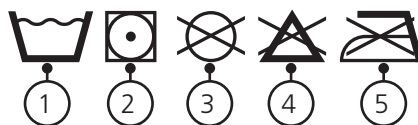

Symboleja:



Valmistaja



Valmistuspäivä. VVVV-
KK-PP (vuosi/kuukausi/
päivä)



CE-merkintä



Katso käyttöopas



Tämä puoli ylöspäin, tämä puoli ulospäin



Käyttäjän enimmäispaino



Lääkinnällinen laite

A

RgoSling Toilet LowBack

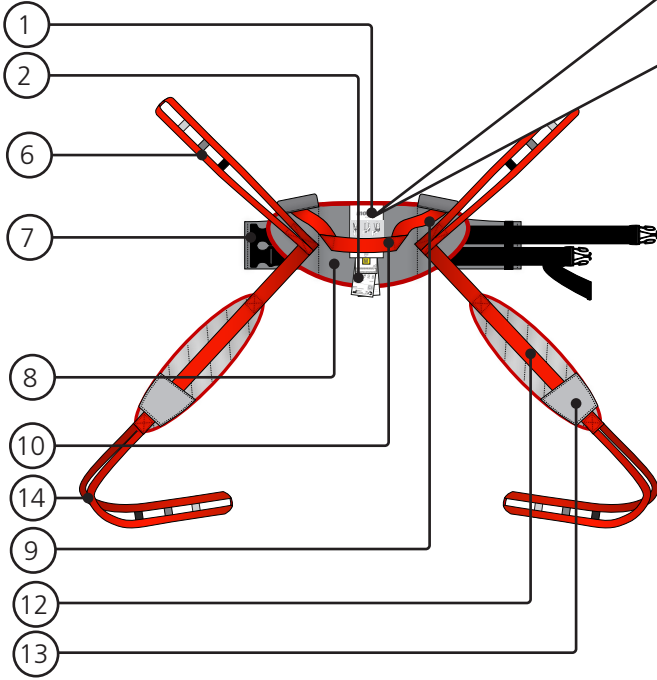

RgoSling Toilet HighBack

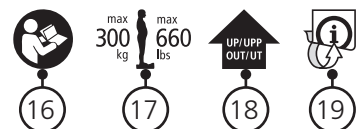
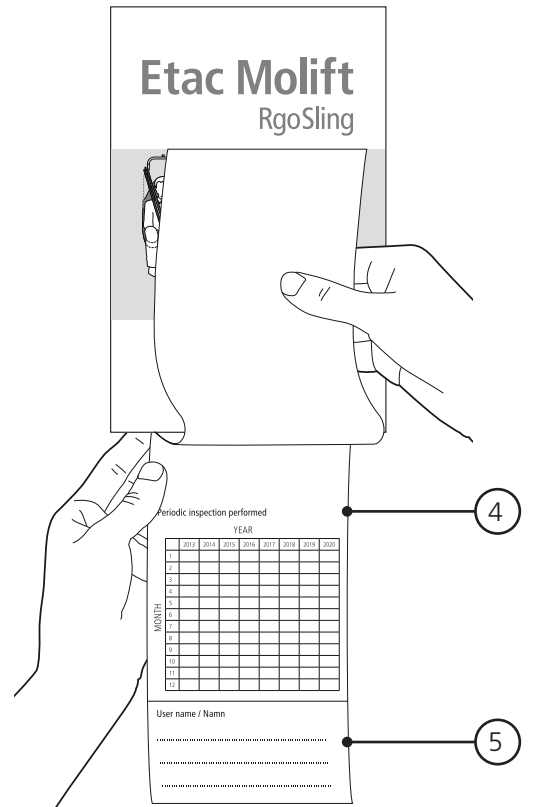
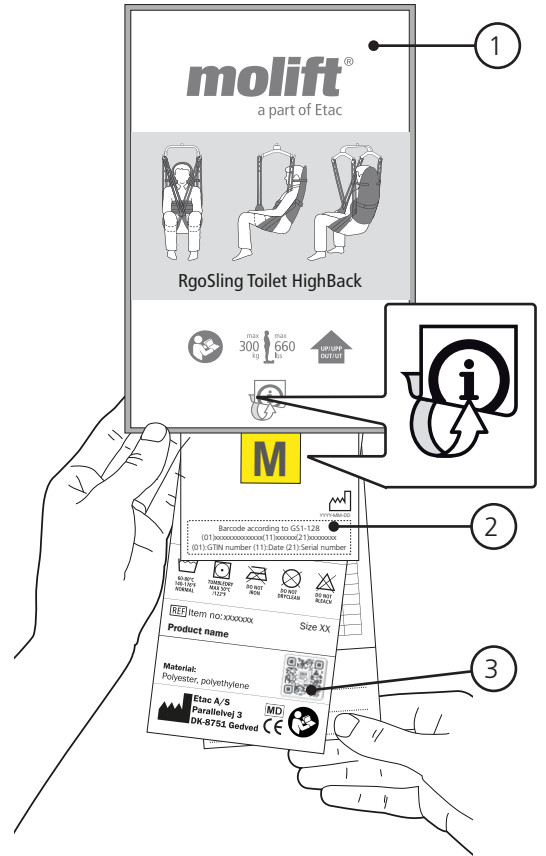
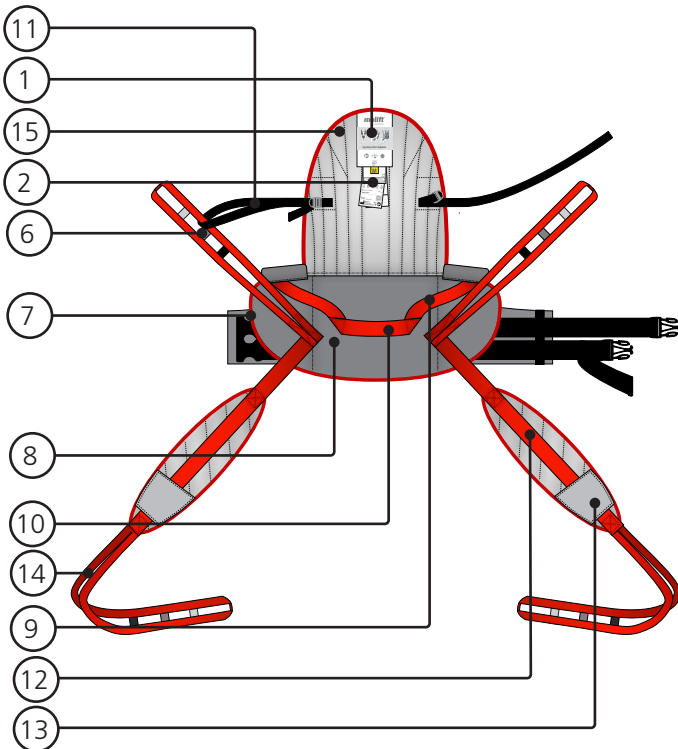

B

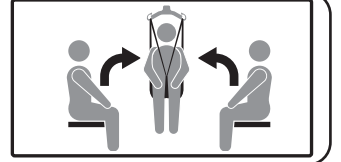

Nostoliinan käyttö

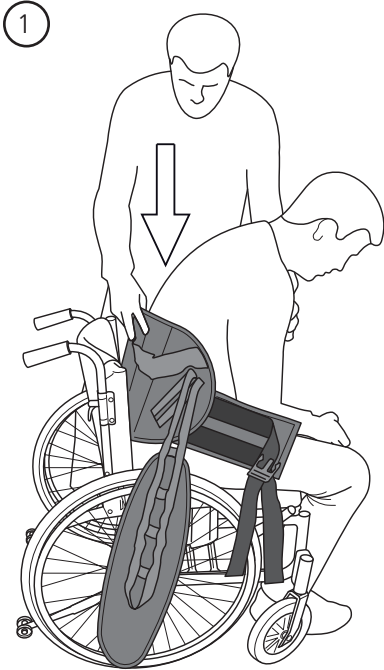

B1. Valmistele käyttäjä avaamalla hänen housunsa napit/vetoketju. Pitele nostoliinaa yhdellä kädellä ja tue käyttäjää toisella kädellä. Liu'uta nostoliina käyttäjän selän taakse. Aseta nostoliina suunnilleen vyötärön korkeudelle selän taakse.

B2. Aseta lantiovyö paikoilleen ja kiristä. Varmista, että housut voidaan riisua pois.

3

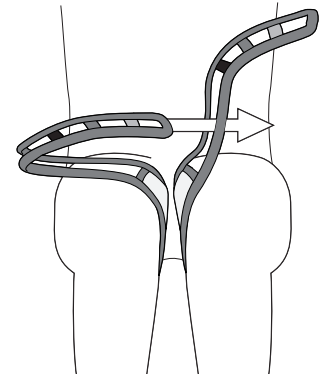
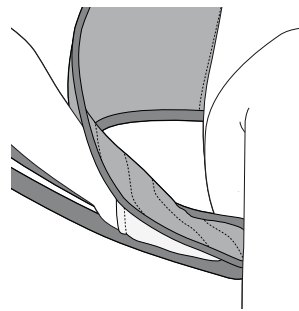
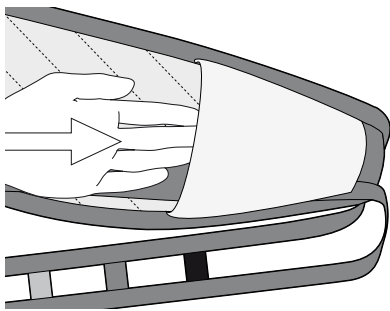

B3. Aseta jalkatuet käyttäjän reisien alle. Jalkatuen ulkoreunassa oleva sovitustasku helpottaa käyttöä. Aseta jalkalenkkit ristikkäin vetämällä toinen lenkeistä toisen läpi.

Nostaminen istuma-asentoon

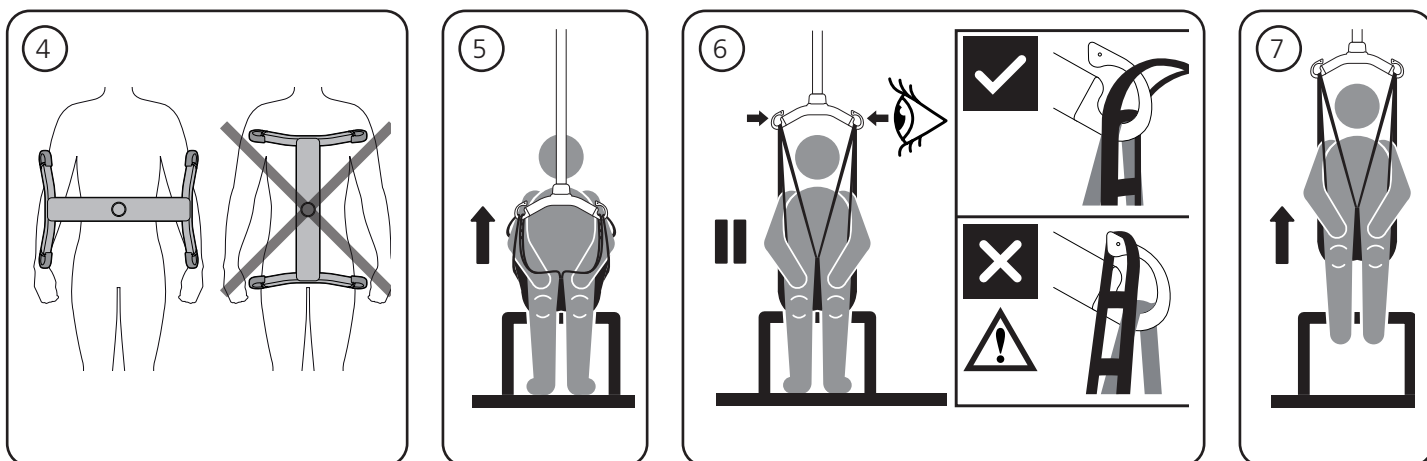

B4. Ripustus on aina asetettava poikittain käyttäjään nähden, jotta estetään käyttäjän liukuminen pois nostoliinasta.

B5. Kiinnitä nostoliina ripustuksen koukkuihin.

B6. Venytä nostoliinan lenkkejä käyttäjää nostamatta. Varmista, että nostoliina on asetettu

oikein käyttäjän ympärille ja että nostolenkit on kiinnitetty oikein ripustuksen koukkuihin.

B7. Älä nosta käyttäjää korkeammalle kuin on tarpeen. Muista, että siirrettävän nostolaitteen pyörät EIVÄT saa olla lukittuina.

Laskeminen istuma-asentoon

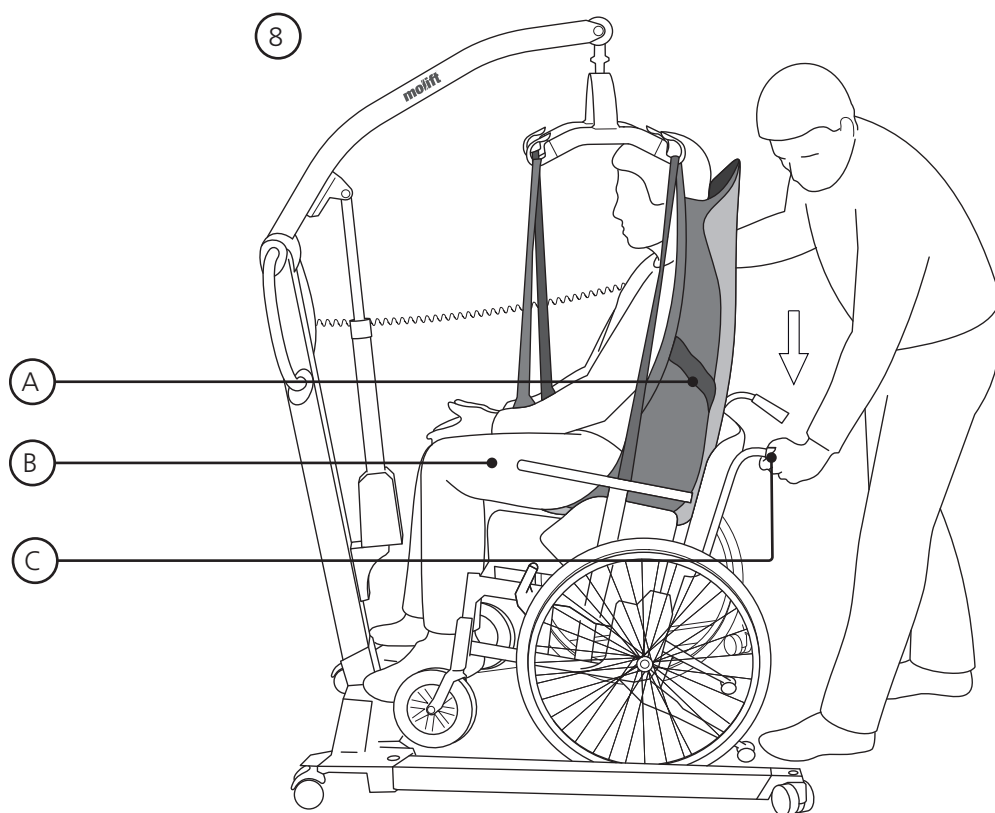

B8. Kun käyttäjä siirretään istuma-asentoon, voit käyttää seuraavia tekniikoita käyttäjän laskemiseen mahdollisimman taakse istuimeen:

A. Aseta käyttäjä oikeaan asentoon ohjauslenkin avulla.

B. Paina käyttäjän polvia varovasti.

C. Kallista istuinta taaksepäin.

C

Nostoliinan säätäminen ja tarkastettavat kohdat

RgoSling Toilet LowBack

- C1. Ripustus on käyttäjän kasvoista poispäin.
- C2. Lantiovyö on lukittu ja kiristetty.
- C3. Ripustuksen jalkalenkit ovat ristikkäin.
- C4. Jalkatuki on asetettu oikein.
- C5. Selkätuki on oikealla korkeudella.

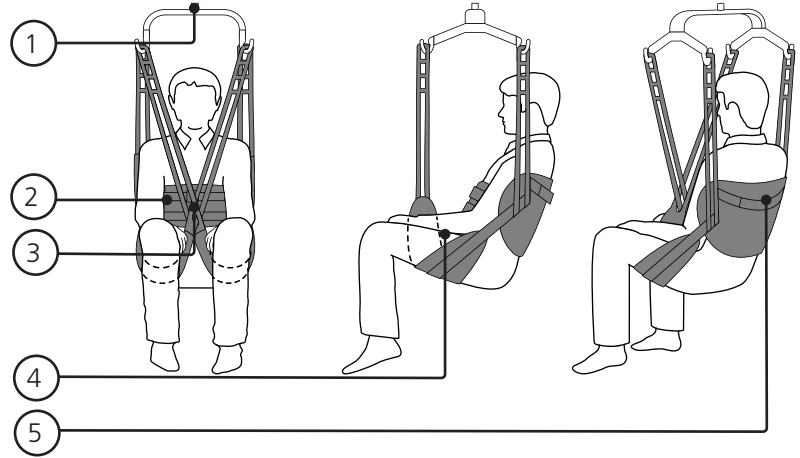

RgoSling Toilet HighBack

- C6. Ripustus on käyttäjän kasvoista poispäin.
- C7. Lantiovyö on lukittu ja kiristetty.
- C8. Ripustuksen jalkalenkit ovat ristikkäin.
- C9. Jalkatuki on asetettu oikein.
- C10. Selkätuki on asetettu oikealle korkeudelle.
- C11. Päätuki on säädetty.

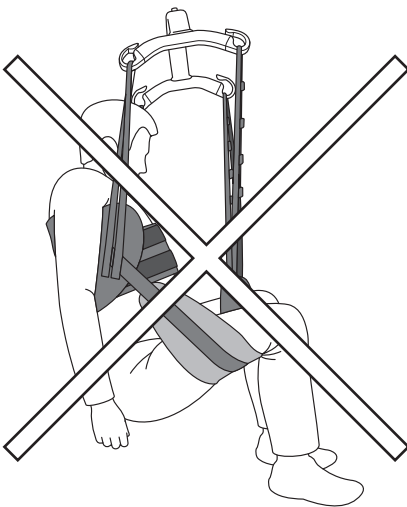
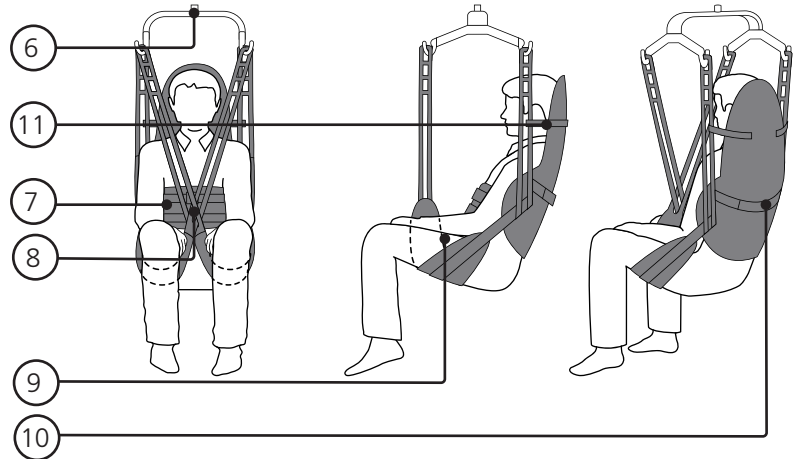

- C12. Virheellinen nostoliinan asento. Takaosa on asetettu liian korkealle ja jalkatuki on liian pitkällä edessä. Tämä tilanne voi tapahtua, jos käyttäjän lihasjänteys ei ole riittävä.

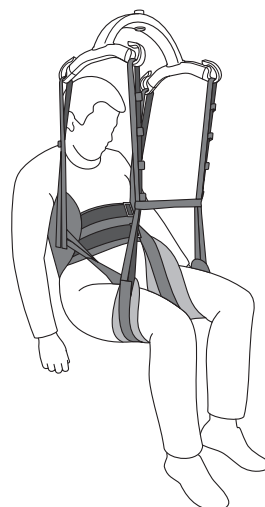

- C13. Jalkatuen vaihtoehtoinen asento käytettäessä apuna jatkohihnoja.

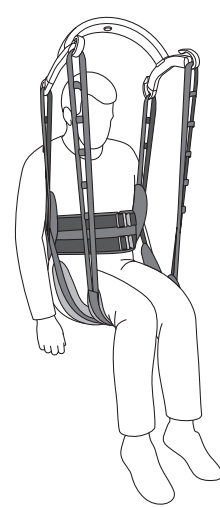

- C14. Jalkatuen vaihtoehtoinen asento, jossa jalkatuet ovat molempien jalkojen alla.

D

Nostoliinan poistaminen

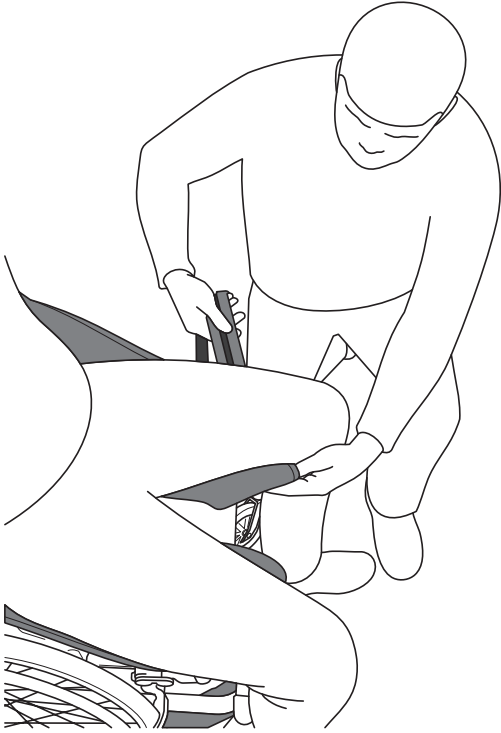



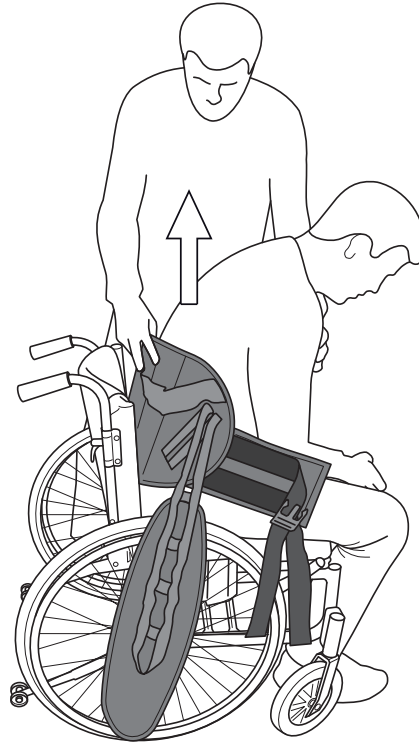







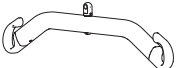

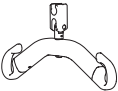
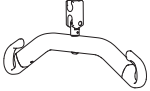
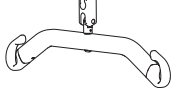

D1. Irrota jalkatuki taittamalla jalkatuki käyttäjän reiden alle ja vetämällä se pois.

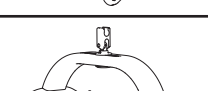

D2. Seiso tuolin vieressä ja nojaa käyttäjää eteenpäin tukemalla häntä samalla toisella kädellä. Vedä nostoliina pois toisella kädellä ja nojaa käyttäjää taaksepäin tuolissa. Jos vedät nostoliinaa voimakkaasti ylöspäin, käyttäjä saattaa kaatua eteenpäin ja loukkaantua. Pidä toista kättä aina käyttäjän ympärillä.

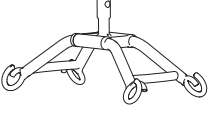
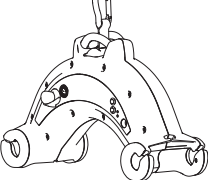
Yhdistelmäluettelo

Ripustus		RgoSling Toilet Lowback / RgoSling Toilet Highback		
		XXS - S	S - L	L - XXL
Mover 180				
	2-pt Small	✓		
	2-pt Medium	✓	✓	
	2-pt Large		✓	
	4-pt Medium	✓	✓	✓
	4-pt Large		✓	✓
Mover 205				
	2-pt Small	✓		
	2-pt Medium	✓	✓	
	2-pt Large		✓	
	4-pt Medium	✓	✓	✓
	4-pt Large		✓	✓
Mover 300				
	4-pt Medium	✓	✓	✓
	4-pt Large		✓	✓
Partner 255				
	4-pt Medium	✓	✓	✓
	4-pt Large		✓	✓

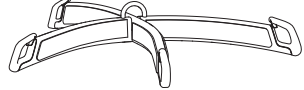
Ripustus		RgoSling Toilet Lowback / RgoSling Toilet Highback		
Smart		XXS - XS	S - L	XL - XXL
	4-pt Medium	✓	✓	✓
Nomad				
	4-pt Medium	✓	✓	✓
Nova				
	2-pt Small	✓		
	2-pt Medium	✓	✓	
	2-pt Large		✓	
	4-pt Medium		✓	✓
	4-pt Large			✓

Nostoliinan koko-opas

Valittava koko riippuu osittain käyttäjän painosta, käyttötarkoituksesta ja vartalon ympärysmittasta/koosta.

Turvallinen työkuormitus (SWL) 300* kg.

Size	Weight (Kg)
XXL	230-300
XL	160-240
L	90-160
M	45-95
S	25-50
XS	17-25
XXS	12-17

Ohjeita ongelmatilanteisiin

Ongelma	Possible Cause/Action
Nostoliina ei sovi käyttäjälle.	Vääränkokoinen nostoliina. Kokeile toista kokoa.
	Nostoliina on liian pieni, jos jalkatuet eivät ylety sisäreiden puoleenväliin ja ripustus on liian lähellä käyttäjän kasvoja. Kokeile toista kokoa.
	Nostoliina on asetettu väärään kohtaan. Vedä nostoliinaa takaosasta riittävästi alaspäin, kun asetat sitä käyttäjälle.
Kaikki lenkit eivät nosta samanaikaisesti.	Jos nostoliinan hihnat nostavat epätasaisesti, nostoliina voi liukua ylös selästä, jolloin käyttäjä saattaa liukua alas nostoliinan aukosta. Varmista, että jalkatuet on asetettu oikein reisien päälle.
Käyttäjä liukuu nostoliinan läpi tai pois siitä.	Nostoliinaa ei ole kiinnitetty oikein yksilöllisen ohjeen mukaisesti.
	Käyttäjän vaatteet ovat liian liukkaat. Vaihda tai riisu osa vaatteista.

Deutsche Bedienungsanleitung

Inhalt

Allgemeines	54
Test und Garantie	54
Sicherheitsmaßnahmen	55
Inspektionen.....	55
Regelmäßige Inspektion	55
Beschreibung	56
Etac Molift RgoSling Toilet LowBack	56
Etac Molift RgoSling Toilet HighBack	56
Pflege/Waschen	56
Sling application	58
Heben.....	59
In eine Sitzposition absenken	59
Einstellungen am Hebetuch und zu überprüfende Punkte	60
Entfernen des Hebetuchs, im Sitzen	61
Verzeichnis der Kombinationsmöglichkeiten	62
Wahl des passenden Hebetuchs.....	62
Fehlersuche und -behebung	63

Wir übernehmen keine Haftung für Druckfehler oder unvollständige Angaben.

Test und Garantie

CE dieses Produkt ist CE-zertifiziert.

Die Molift-Hebetücher von Etac wurden von anerkannten Prüfstellen geprüft und entsprechen den in der Medizinprodukterichtlinie MDR (EU) 2017/745 formulierten Anforderungen für Produkte der Klasse 1. Darüber hinaus erfüllen die Hebetücher die in der Norm EN ISO 10535 aufgeführten Anforderungen.

Garantie: Zwei Jahre auf Material- und Herstellungsfehler bei ordnungsgemäßem Gebrauch.

Weitere Informationen über das Angebot an Molift-Hebetüchern und -Liftern von Etac finden sie auf www.molift.com

Anbringen des Hebetuchs

Danke, dass Sie sich für ein Molift-Hebetuch von Etac entschieden haben.

Die Bedienungsanleitung muss sorgfältig gelesen werden, um Beschädigungen bei Handhabung und Gebrauch des Produkts zu vermeiden.

In dieser Bedienungsanleitung ist der „Benutzer“ diejenige Person, die gehoben wird. Der „Helfer“ ist diejenige Person, die das Hebetuch bedient.



Dieses Symbol ist in der Bedienungsanleitung mit dazugehörigem Text zu finden. Es zeigt an, dass Vorsicht geboten ist, wenn die Sicherheit des Benutzers oder des Helfers gefährdet ist.

Etac arbeitet kontinuierlich an der Verbesserung seiner Produkte. Wir behalten uns deshalb das Recht vor, jederzeit Änderungen an unseren Produkten ohne vorherige Ankündigung vorzunehmen.



Weitere Informationen, Beratung und aktuelle Dokumentationen finden Sie auf www.molift.com

Sicherheitsmaßnahmen



Die Bedienungsanleitungen für den Lifter als auch für das Hebetuch müssen vor Gebrauch sorgfältig gelesen werden, um Verletzungen während Handhabung und Gebrauch des Produkts zu vermeiden.

Es ist wichtig, dass das Hebetuch mit jedem einzelnen Benutzer und für jede Hebesituation individuell getestet wird. Entscheiden Sie, ob mehr als ein Helfer benötigt wird.

Planen Sie den Hebetransport im Voraus, um sicherzustellen, dass alles so sicher und störungsfrei wie nur möglich abläuft. Denken Sie an eine ergonomische Arbeitsweise.

Bewerten Sie die Risiken und machen Sie sich entsprechende Notizen. Sie als Pfleger/Betreuer sind für die Sicherheit des Benutzers verantwortlich.



Heben Sie einen Benutzer niemals vom Startpunkt aus höher an, als für die Durchführung des Hebetransports unbedingt notwendig ist. Lassen Sie den Benutzer während des Hebetransports niemals unbeaufsichtigt.



Stellen Sie stets sicher, dass der Benutzer über die erforderlichen Fähigkeiten zur Benutzung des betreffenden Hebetuchs verfügt,

- Modell, Größe und Material sind geeignet
- Das Hebetuch eignet sich für den eingesetzten Lifter bzw. die eingesetzte Aufhängung.
- Es ist wichtig, vor dem Heben des Benutzers sicherzustellen, dass die Hebeschlaufen ordnungsgemäß an den Haken der Aufhängung befestigt sind.
- Stellen Sie sicher, dass die Räder von Rollstuhl, Bett oder Bahre während des Hebetransports verriegelt sind, soweit erforderlich.

Inspektionen

Das Hebetuch muss regelmäßig untersucht werden, vorzugsweise vor jedem Hebetransport, vor allem aber nach jedem Waschen.

- Stellen Sie dabei sicher, dass Nähte, Stoff, Bänder und Schlaufen nicht verschlissen oder beschädigt sind.



Benutzen Sie niemals ein fehlerhaftes oder beschädigtes Hebetuch, da dies reißen und zu Verletzungen führen kann. Zerstören und entsorgen Sie beschädigte und alte Hebetücher



Das Hebetuch sollte nicht in direktem Sonnenlicht gelagert werden.

Regelmäßige Inspektion

Die regelmäßige Inspektion muss mindestens alle 6 Monate durchgeführt werden. Wenn das Hebetuch über den normalen Gebrauch hinaus öfters eingesetzt oder gewaschen wird, ist es ggf. notwendig, die Inspektionen häufiger durchzuführen. Informationen zur regelmäßigen Inspektion finden Sie auf www.molift.com

Beschreibung

Der Molift von Etac bietet eine breite Auswahl von Hebetüchern für Transportaufgaben aller Art an. Das Hebetuch Molift RgoSling von Etac ist darauf ausgelegt, Gewicht und Druck im Hinblick auf größtmöglichen Komfort gleichmäßig zu verteilen.

Mit Hilfe eines Führungsgriffs kann der Benutzer in die richtige Sitzposition gebracht werden. Er kommt ausschließlich dann zum Einsatz, wenn sich der Benutzer im Hebemodus befindet. Das Hebetuch Molift RgoSling von Etac kann sowohl mit einer 4-Punkt-Aufhängung als auch mit einer 2-Punkt-Aufhängung kombiniert werden. Die korrekten Kombinationsmöglichkeiten für die einzelnen Hebetücher und Aufhängungen finden Sie im Verzeichnis der Kombinationsmöglichkeiten. Molift RgoSling Toilet ist in den Größen XXS – XXL mit Polyesterpolsterung erhältlich.

Etac Molift RgoSling Toilet LowBack
Molift RgoSling Toilet LowBack von Etac hat eine niedrige Rückenpartie und eine Oberschenkelauflage mit einer breiten Öffnung. Das Hebetuch kann sowohl für das Heben in eine Sitzposition als auch aus einer Sitzposition heraus eingesetzt werden.

Etac Molift RgoSling Toilet HighBack
Molift RgoSling Toilet HighBack von Etac verfügt über eine hohe Rückenpartie und eine getrennte Oberschenkelauflage mit einer mittelgroßen Öffnung. Das Hebetuch verfügt über eine Kopfstütze. Das Hebetuch kann sowohl für das Heben in eine Sitzposition als auch aus einer Sitzposition heraus eingesetzt werden.

RgoSling Toilet LowBack und RgoSling Toilet HighBack eignen sich nicht für Personen mit einem niedrigen Muskeltonus. Es besteht ein hohes Risiko, dass Patienten mit zu niedrigem Muskeltonus aus dem Hebetuch herausgleiten, da das Hebetuch eine breite Öffnung hat.

Das Produkt hat eine voraussichtliche Lebensdauer von 1 bis 5 Jahren bei normalem Gebrauch. Die Lebensdauer des Produkts variiert und hängt von der Häufigkeit des Gebrauchs, der Materialbeschaffenheit, der Belastung und davon ab, wie oft es gewaschen wird.

- A1. Produktetikett
- A2. (01) EAN-code
xxxxxxxxxxxxxxxxxx
(21) Seriennummer
xxxxxxxx
- A3. QR-code
- A4. Etikett: Regelmäßige Inspektion
- A5. Etikett: Benutzername
- A6. Obere Hebeschlaufe
- A7. Taillengurt
- A8. Polsterung
- A9. Führungsgriff, seitlich
- A10. Führungsgriff, rückseitig
- A11. Einstellung der Kopfstütze
- A12. Oberschenkelauflage
- A13. Anlegetasche, Bein
- A14. Untere Hebeschlaufen
- A15. Kopfstütze
- A16. Symbol: Vor dem Gebrauch die Bedienungsanleitung lesen
- A17. Symbol: Maximales Benutzergewicht
- A18. Symbol: Diese Seite des Produkts wird nach oben und nach außen gedreht
- A19. Symbol: Aufklappen - Weitere Informationen befinden sich auf der Innenseite

Pflege/Waschen

Lesen Sie die Pflegeanweisungen für das Produkt.

1. Mit Wasser waschbare Hebetücher können bei Temperaturen von 60° C bis 85° C gewaschen werden.



Waschen bei höheren Temperaturen hat einen schnelleren Materialverschleiß zur Folge.

2. Trockenschleudern bei max. 45° C. Sterilisation für 30 Minuten bei 85 °C
3. Nicht chemisch reinigen.
4. Nicht bleichen.
5. Nicht bügeln.

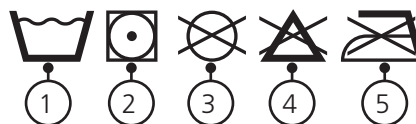

Symbole:



Hersteller



Herstellungsdatum. JJJJ-MM-DD
(Jahr/Monat/tag)



CE-konform



Lesen Sie die Bedienungsanleitung



Hier oben, diese Seite ist außen



max 255 kg max 560 lbs
Max. Benutzergewicht (Tragfähigkeit)



Medizinprodukt

A

RgoSling Toilet LowBack

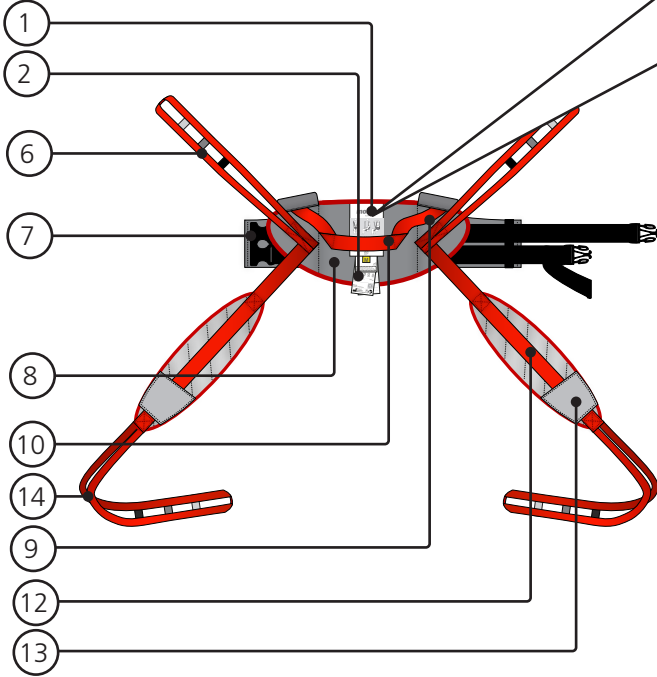

RgoSling Toilet HighBack

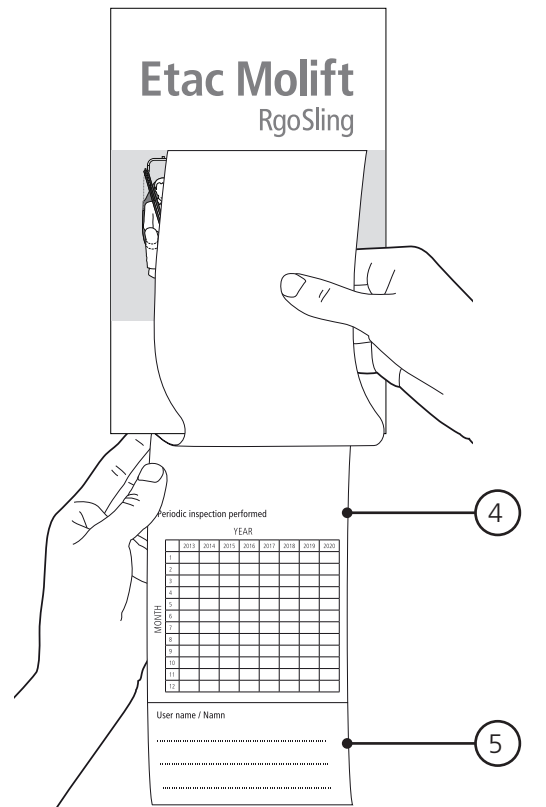
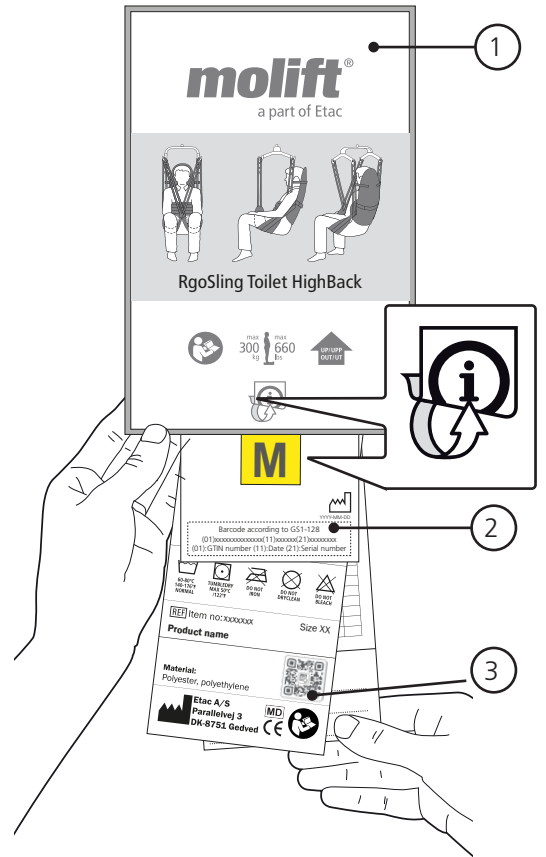
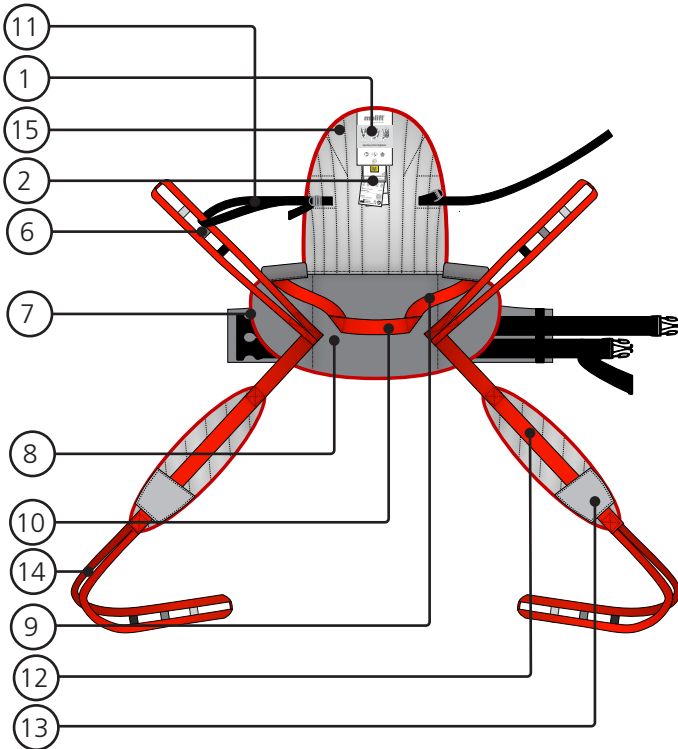

B

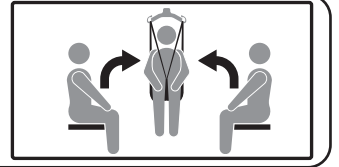

Anbringen des Hebetuchs

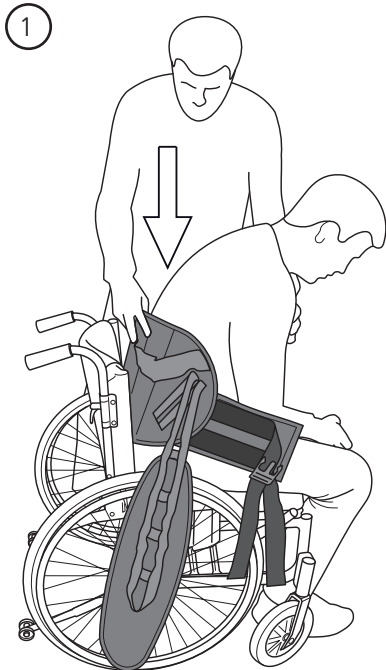

B1. Bereiten Sie den Benutzer vor, indem Sie seine Hose aufknöpfen. Halten Sie das Hebetuch mit einer Hand und stützen Sie mit der anderen Hand den Benutzer. Führen Sie das Hebetuch hinter dem Rücken des Benutzers hinunter. Platzieren Sie das Hebetuch etwa in Taillenhöhe am Rücken.

B2. Schließen Sie den Taillengurt und ziehen Sie ihn fest. Stellen Sie sicher, dass die Hose zugänglich ist.

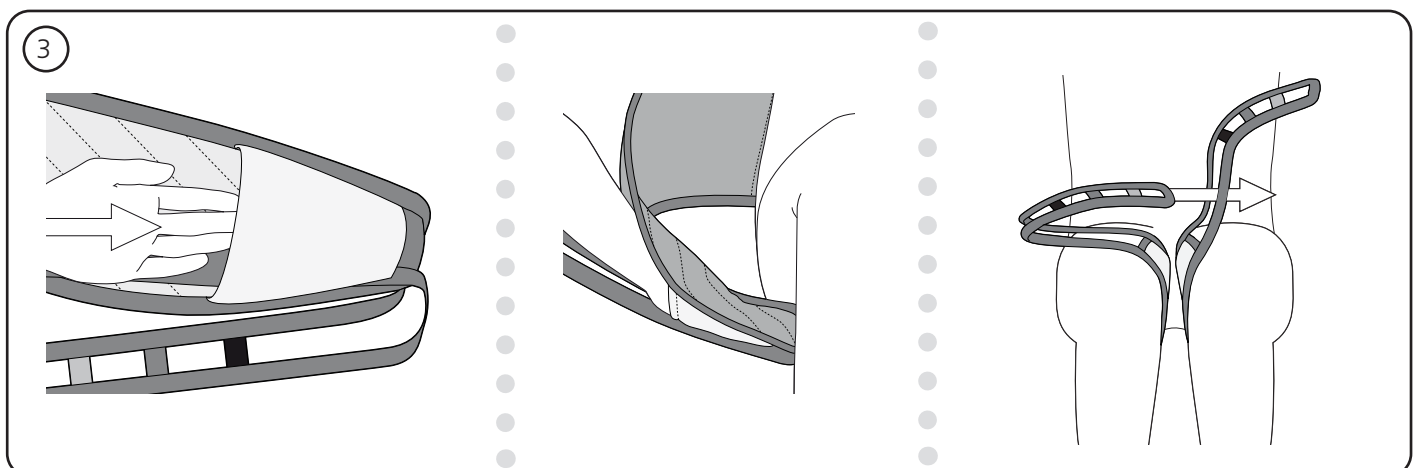

B3. Positionieren Sie die Oberschenkelauflagen unter den Oberschenkeln des Benutzers. Die Anlegetasche am Ende der Oberschenkelauflage erleichtert diesen Vorgang. Führen Sie eine Schlaufe durch die andere und kreuzen Sie so die beiden Beinschlaufen.

Heben

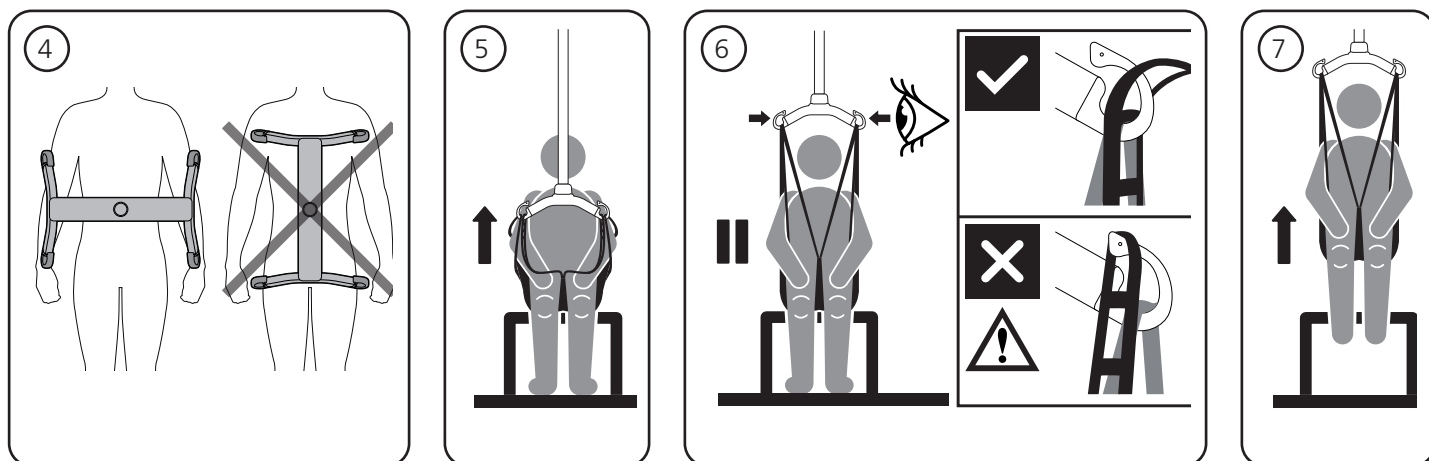

- B4. Die Aufhängung muss immer horizontal zum Benutzer ausgerichtet sein, um zu verhindern, dass der Benutzer aus dem Hebetuch rutscht.
- B5. Hängen Sie das Hebetuch in die Haken der Aufhängung ein.
- B6. Ziehen Sie die Schlaufengurte des Hebetuchs an, ohne dabei den Benutzer anzuheben. Stellen Sie sicher, dass das Hebetuch

- ordnungsgemäß am Benutzer anliegt und die Gurtschlaufen ordnungsgemäß an den Aufhängungshaken befestigt sind.
- B7. Heben Sie den Benutzer nur soweit an, wie es notwendig ist. Vergessen Sie nicht, dass die Räder eines mobilen Lifters NICHT blockiert sein dürfen.

In eine Sitzposition absenken

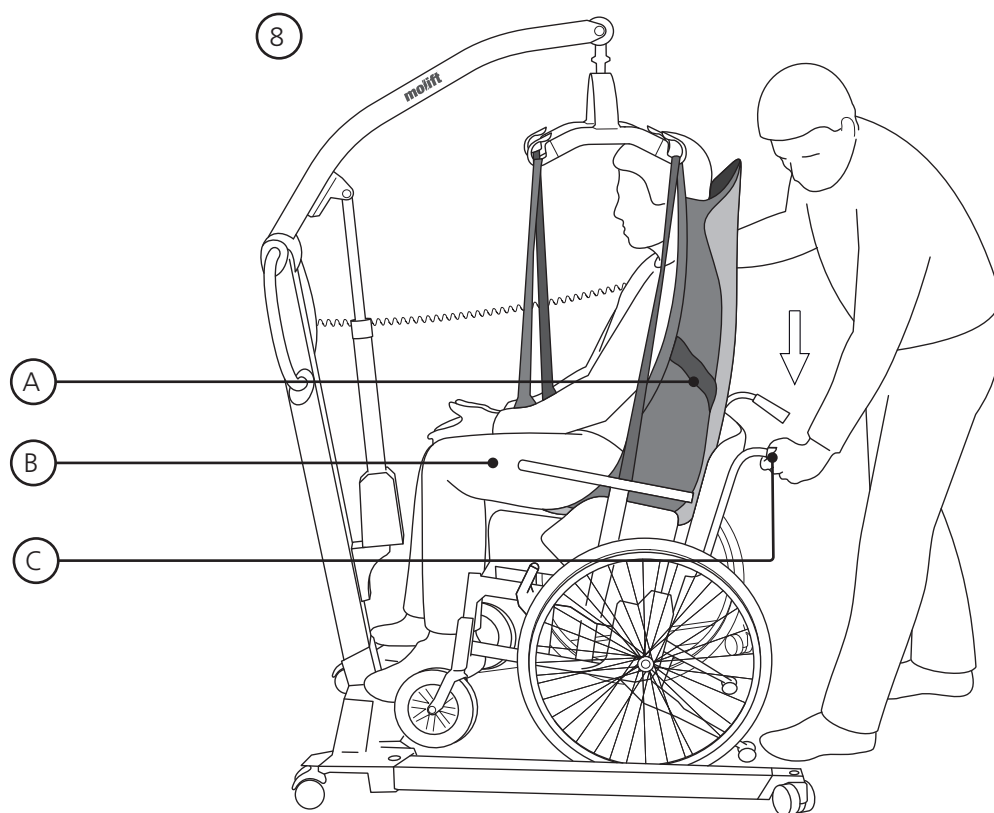

- B8. Um den Benutzer in eine Sitzposition zu bringen, können die folgenden Techniken angewandt werden, während der Benutzer so weit wie möglich zurück in den Sitz abgesenkt wird:

- A. Positionieren Sie den Benutzer mithilfe des Steuergriffs
- B. Drücken Sie sanft gegen die Knie des Benutzers
- C. Neigen Sie den Sitz nach hinten

C

Einstellungen am Hebetuch und zu überprüfende Punkte

RgoSling Toilet LowBack

- C1. Stellen Sie sicher, dass die Aufhängung nicht in der Nähe des Gesichts des Benutzers ist
- C2. Geschlossener und festgezogener Taillengurt
- C3. Aufhängeschlaufen überkreuzen
- C4. Korrekt platzierte Oberschenkelauflage
- C5. In korrekter Höhe platzierter Rücken

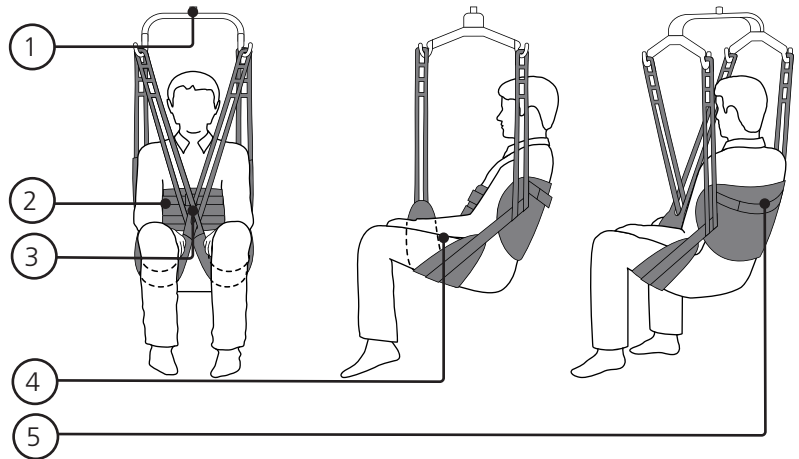

RgoSling Toilet High-

- C6. Stellen Sie sicher, dass die Aufhängung nicht in der Nähe des Gesichts des Benutzers ist
- C7. Geschlossener und festgezogener Taillengurt
- C8. Aufhängeschlaufen überkreuzen
- C9. Korrekt platzierte Oberschenkelauflage
- C10. In korrekter Höhe platzierter Rücken
- C11. Einstellung der Kopfstütze

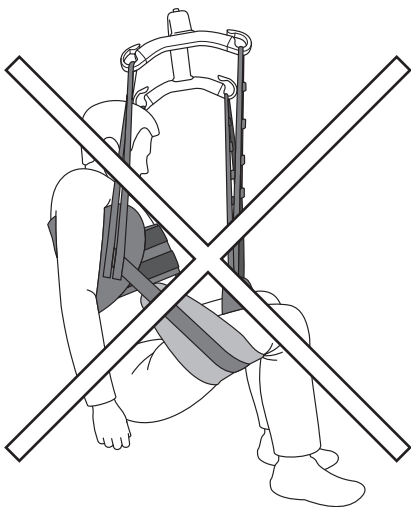
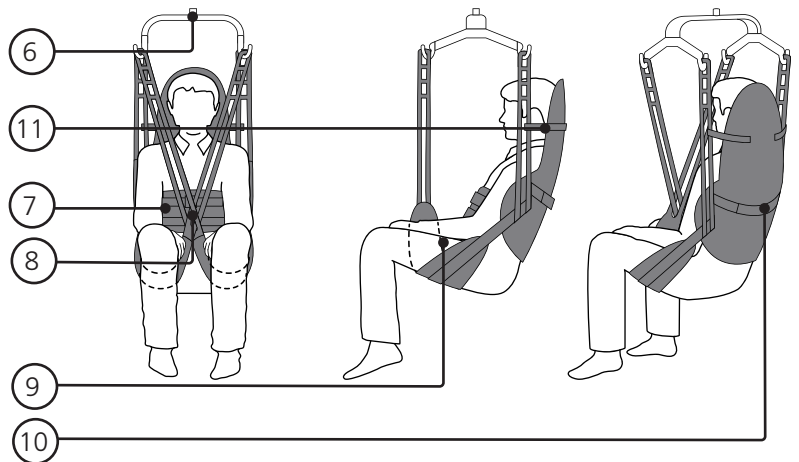

- C12. Falsche Positionierung des Hebetuchs. Die Rückenpartie ist zu hoch und die Oberschenkelaufgabe zu weit vorne angebracht. Dazu kann es auch kommen, wenn der Benutzer zu wenig Muskeltonus hat.

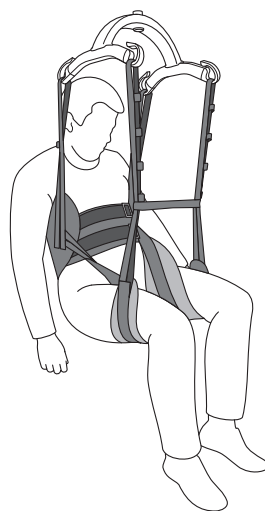

- C13. Alternative Platzierung der Oberschenkelaufgabe durch zusätzliche Verlängerungsschlaufen.

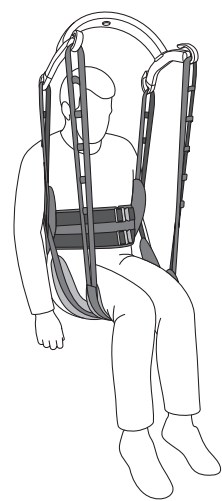

- C14. Alternative Platzierung der Oberschenkelaufgabe mit beiden Oberschenkelaufgaben unter beiden Beinen

D

Entfernen des Hebetuchs, im Sitzen

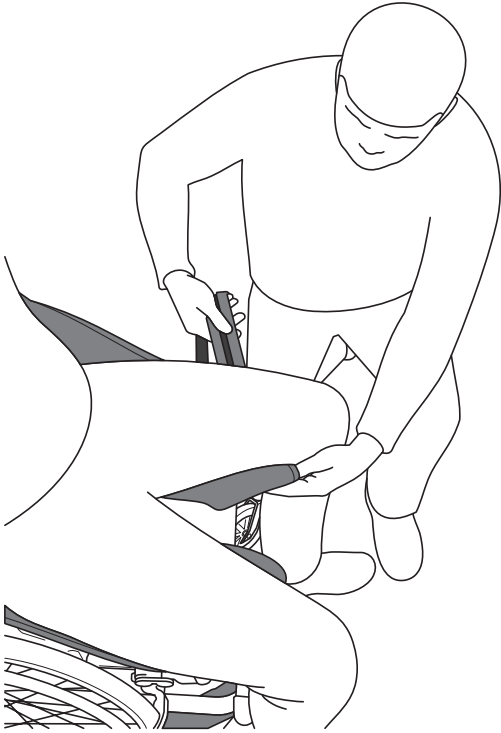



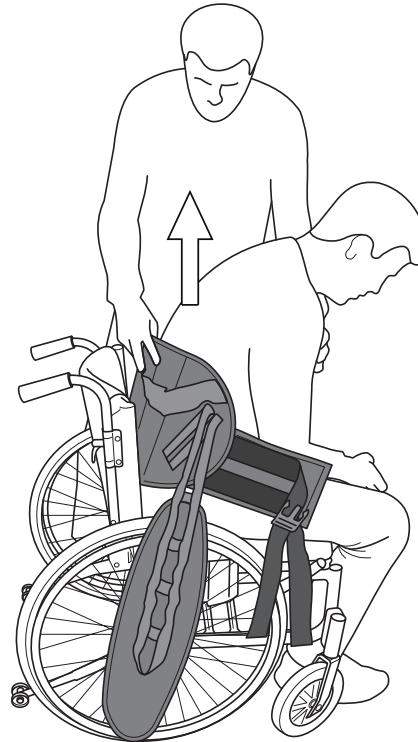







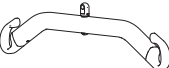

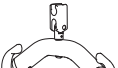
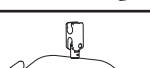
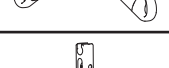

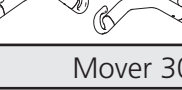

D1. Entfernen Sie die Oberschenkelauflage, indem Sie sie unter dem Oberschenkel des Benutzers unter das Hebetuch falten, und ziehen Sie sie heraus.

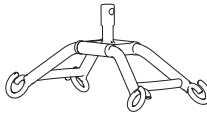
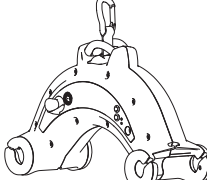

D2. Stellen Sie sich neben den Stuhl und neigen Sie den Benutzer nach vorne. Halten Sie ihn dabei mit einer Hand. Ziehen Sie das Hebetuch mit einer Hand weg und lehnen Sie den Benutzer wieder zurück in den Stuhl. Wenn Sie zu fest an dem Hebetuch ziehen, kann der Benutzer nach vorne fallen und sich verletzen. Stützen Sie den Benutzer stets mit einer Hand.

Verzeichnis der Kombinationsmöglichkeiten

Aufhängung		RgoSling Toilet Lowback / RgoSling Toilet Highback		
		XXS - S	S - L	L - XXL
Mover 180				
	2-pt Small	✓		
	2-pt Medium	✓	✓	
	2-pt Large		✓	
	4-pt Medium	✓	✓	✓
	4-pt Large		✓	✓
Mover 205				
	2-pt Small	✓		
	2-pt Medium	✓	✓	
	2-pt Large		✓	
	4-pt Medium	✓	✓	✓
	4-pt Large		✓	✓
Mover 300				
	4-pt Medium	✓	✓	✓
	4-pt Large		✓	✓
Partner 255				
	4-pt Medium	✓	✓	✓
	4-pt Large		✓	✓

Aufhängung		RgoSling Toilet Lowback / RgoSling Toilet Highback		
		XXS - XS	S - L	XL - XXL
Smart				
	4-pt Medium	✓	✓	✓
Nomad				
	4-pt Medium	✓	✓	✓
Nova				
	2-pt Small	✓		
	2-pt Medium	✓	✓	
	2-pt Large		✓	
	4-pt Medium		✓	✓
	4-pt Large			✓

Wahl des passenden Hebetuchs

Die Wahl des Hebetuchs hängt zum Teil vom Gewicht sowie von Körperform bzw. Größe des Benutzers ab.

Die Tragfähigkeit (SWL, Safe Working Load) beträgt 300kg.

Größe	Gewicht (Kg)
XXL	230-300
XL	160-240
L	90-160
M	45-95
S	25-50
XS	17-25
XXS	12-17

Fehlersuche und -behebung

Symptom	Mögliche Ursache / Maßnahme
Das Hebetuch passt dem Benutzer nicht.	Falsche Hebetuchgröße. Probieren Sie eine andere Größe aus.
	Das Hebetuch ist zu klein, wenn die Oberschenkelauflagen nicht bis zur Mitte um die Schenkelinnenseiten herum reichen und die Aufhängung sich zu nah am Gesicht des Benutzers befindet. Probieren Sie eine andere Größe aus.
	Das Hebetuch ist nicht richtig positioniert. Führen Sie das Hebetuch beim Anpassen tief genug in den Rückenbereich ein.
Es werden nicht alle Schlaufen gleichzeitig angehoben.	Wenn die Schlaufen nicht gleichmäßig angehoben werden, bedeutet dies, dass sich das Hebetuch im Rückenbereich stärker anhebt und der Benutzer dadurch nach unten in die Öffnung des Hebetuchs rutscht. Stellen Sie sicher, dass die Oberschenkelauflagen ordnungsgemäß um die Oberschenkel herum angelegt sind.
Der Benutzer rutscht durch/aus dem Hebetuch.	Das Hebetuch wurde nicht den individuellen Verordnungen entsprechend korrekt angepasst.
	Der Benutzer trägt zu rutschige Kleidung. Wechseln Sie die Kleidung oder nehmen Sie das Kleidungsstück ab

Nederlandse handleiding

Inhoud

Algemeen	64
Test en garantie.....	64
Veiligheidsmaatregelen	65
Inspectie.....	65
Periodieke inspectie	65
Beschrijving	66
Etac Molift RgoSling Toilet LowBack	66
Etac Molift RgoSling Toilet HighBack	66
Verzorging/wassen	66
Sling aanbrengen	68
Tillen.....	69
In zitpositie laten zakken.....	69
Sling verstellen en controlepunten	70
Sling verwijderen.....	71
Combinatielijst	72
Handleiding sling.....	72
Problemen oplossen	73

Test en garantie

CE dit product heeft de CE-markering.

Etac Molift-slings zijn getest door erkende testinstituten en voldoen aan de normen zoals vastgelegd in de Richtlijn Medische Hulpmiddelen voor producten van klasse 1MDR (EU) 2017/745. De slings voldoen aan de specificaties van de EN ISO 10535 norm.

Garantie: Twee jaar op materiaal- en productie-fouten bij correct gebruik.

Kijk op www.molift.com voor meer informatie over het Molift-assortiment slings van Etac.

Algemeen

Bedankt dat u voor een Molift-sling van Etac hebt gekozen.

Lees deze handleiding aandachtig door om schade bij het hanteren en gebruik van het product te voorkomen.

In deze handleiding is de gebruiker de persoon die wordt getild. De assistent is de persoon die de sling bedient.



Dit symbool wordt samen met tekst in de handleiding weergegeven. Het wijst erop dat voorzichtigheid is geboden in verband met de veiligheid van de gebruiker of de assistent.

Etac verbetert zijn producten voortdurend. Daarom behouden wij ons het recht voor om de producten zonder kennisgeving vooraf aan te passen.



Ga naar www.molift.com voor meer informatie, advies en eventuele documentatie-updates.

Wij zijn niet verantwoordelijk voor drukfouten of onvolledigheden in de tekst.

Veiligheidsmaatregelen



Voorafgaand aan het gebruik dient u de handleidingen van de lift en de sling aandachtig door te lezen om letsel bij het gebruiken van het product te voorkomen.

tie te worden uitgevoerd. Het kan noodzakelijk zijn om dit interval te verkorten als de sling met een hoge frequentie wordt gebruikt of gewassen. Zie het periodieke inspectieformulier op www.molift.com

Het is belangrijk dat de sling eerst wordt getest met de individuele gebruiker en voor de bedoelde tilsituatie. Beoordeel of er een of meerdere assistenten nodig zijn.

Plan de tilhandeling vooraf zodat ze zo veilig en probleemloos mogelijk verloopt. Vergeet niet om ergonomisch te werken.

Evalueer de risico's en maak notities. Als verzorger bent u verantwoordelijk voor de veiligheid van de gebruiker.



Til een gebruiker nooit hoger dan noodzakelijk is om de transfer te kunnen uitvoeren. Laat de gebruiker tijdens het tillen nooit alleen achter.



Controleer altijd of de gebruiker geschikt is voor de betreffende sling.

- Of het model, de maat en het materiaal geschikt zijn.
- Of de sling geschikt is voor de tilmanoeuvre/ ophanging.
- Controleer voordat de gebruiker wordt getild, altijd of de bandlussen correct aan de haken van de ophanging zijn bevestigd.
- Zorg dat alle wielen van de rolstoel of het bed vergrendeld zijn als dit voor het transferproces noodzakelijk is.

Inspectie

De sling moet regelmatig worden geïnspecteerd, bij voorkeur voor elke tilmanoeuvre, maar met name ook nadat hij is gewassen.

- Controleer of naden, stof, banden en lussen geen slijtage of beschadigingen vertonen.



Gebruik nooit een versleten of beschadigde sling omdat dit tot letsel bij de patiënt kan leiden. Vernietig en dank beschadigde en oude slings af.



Bewaar de sling niet op een plek waar hij aan direct zonlicht wordt blootgesteld.

Periodieke inspectie

Om de 6 maanden dient er een periodieke inspec-

Beschrijving

Etac Molift heeft een breed assortiment slings voor verschillende transfertypes. De Etac Molift RgoSling is ontworpen voor een gelijkmatige last/gewicht-ratio, voor een optimaal gebruikscomfort.

Er is een geleiderhandgreep om de gebruiker in de juiste zitpositie te manoeuvreren. Die wordt alleen gebruikt in de tilmodus.

De Etac Molift RgoSling is ontwikkeld voor gebruik met een 4-punts slingstang, maar kan ook met een 2-punts slingstang worden gebruikt. Raadpleeg de combinatielijst om de juiste sling en slingstang te combineren.

Molift RgoSling Toilet is leverbaar in de maten XXS-XXL, in gepolsterd polyester.

Etac Molift RgoSling Toilet LowBack

Etac Molift RgoSling Toilet LowBack heeft een lage rug en een beensteun in twee delen met een grote opening. De sling kan worden gebruikt om personen in en uit een zittende positie te tillen.

Etac Molift RgoSling Toilet HighBack

Etac Molift RgoSling Toilet HighBack heeft een hoge rug en een beensteun in twee delen met een middelgrote opening. De sling heeft een hoofdsteen. De sling kan worden gebruikt om personen in en uit een zittende positie te tillen.

De RgoSling Toilet LowBack en RgoSling Toilet HighBack zijn niet geschikt voor personen met een lage spierspanning. Omdat de sling een grote opening heeft, kunnen patiënten met een lage spierspanning mogelijk uit de sling glijden.

Het product heeft bij normaal gebruik een levensduur van 1 tot 5 jaar. De levensduur van het product varieert naar gelang het gebruik, de materialen, belasting en hoe vaak het wordt gewassen.

- A1. Productlabel
- A2. (01) EAN-code
xxxxxxxxxxxxxx
(21) Serial number
xxxxxxx
- A3. QR-code
- A4. Label: Periodieke inspectie
- A5. Label: Gebruikersnaam
- A6. Bandlus boven
- A7. Gordel
- A8. Vulling
- A9. Geleiderhandgreep, zij
- A10. Geleiderhandgreep, rug
- A11. Verstellen hoofdsteen
- A12. Beensteun
- A13. Plaatsingspocket, been
- A14. Bandlussen onder
- A15. Hoofdsteen
- A16. Symbool: Lees de handleiding voor het gebruik
- A17. Symbool: Max. gewicht gebruiker
- A18. Symbool: Deze zijde van het product naar boven en naar buiten plaatsen
- A19. Symbool: Uitvouwen voor meer informatie

Verzorging/wassen

Lees de aanwijzingen over de verzorging van het product.

1. In water wasbare slings kunnen worden gewassen op een temperatuur van 60 tot 85 °C.
 Door op een hogere temperatuur te wassen, zal het materiaal eerder verslijten.
2. Wasdroger op max. 45 °C.
Autoclaveerbaar op 85 graden gedurende 30 minuten
3. Niet chemisch reinigen
4. Niet bleken.
5. Niet strijken.

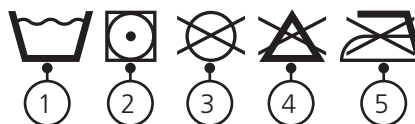

Symbolen:



Fabrikant



PProductie-
datum JJJJ-MM-DD
(jaar/maand/tag)



CE-markering



Zie de bedienings-
handleiding



Deze kant boven,
dit is de buitenkant



max 255 kg
max 560 lbs
Max. gewicht gebruiker
(veilige belasting):



Medisch hulpmiddel

EN
SV
NO
DA
FI
DE
NL
FR
IT
ES

A

RgoSling Toilet LowBack

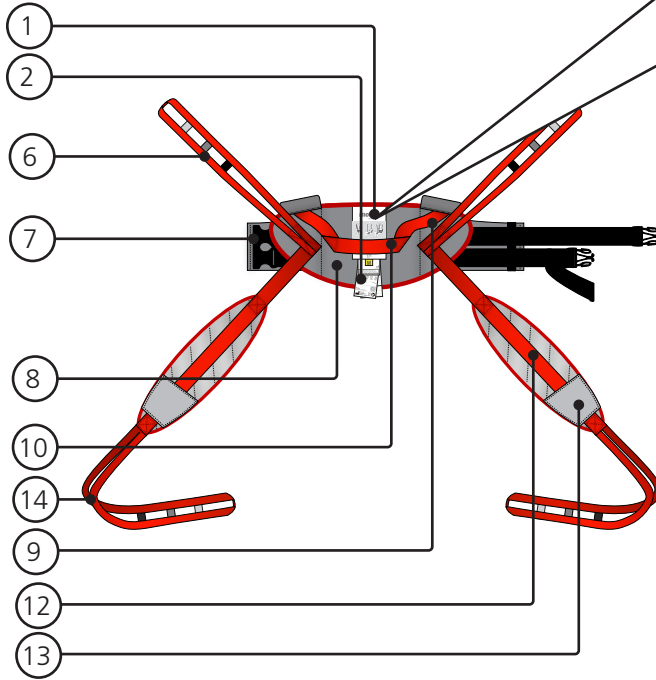

RgoSling Toilet HighBack

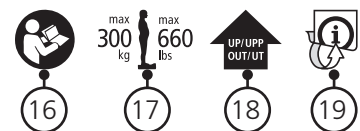
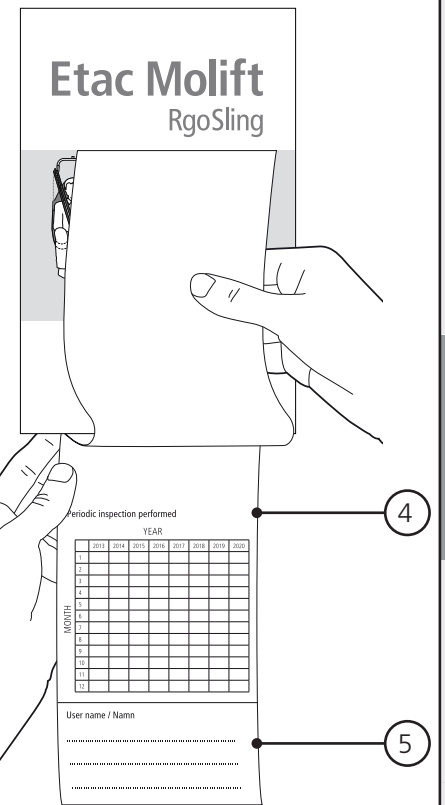
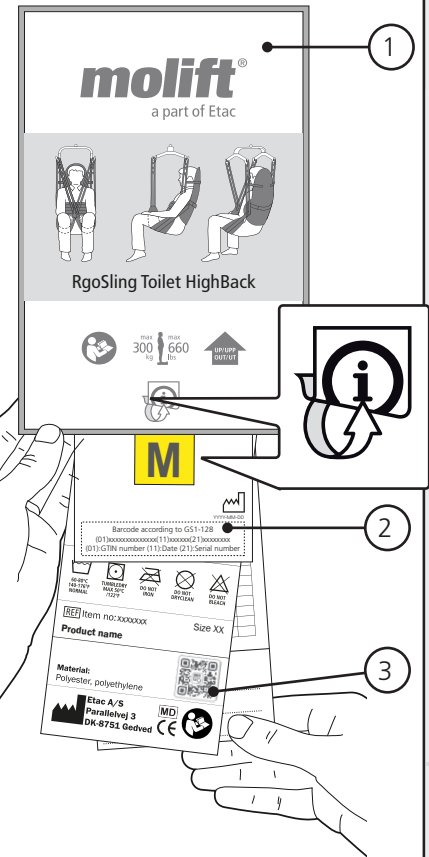
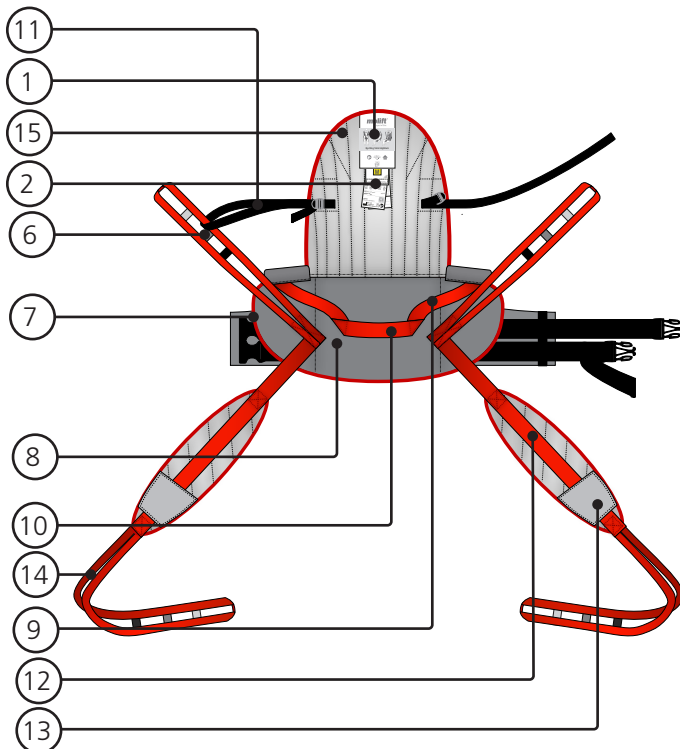

B

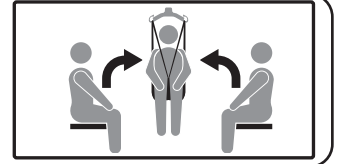

Sling aanbrengen

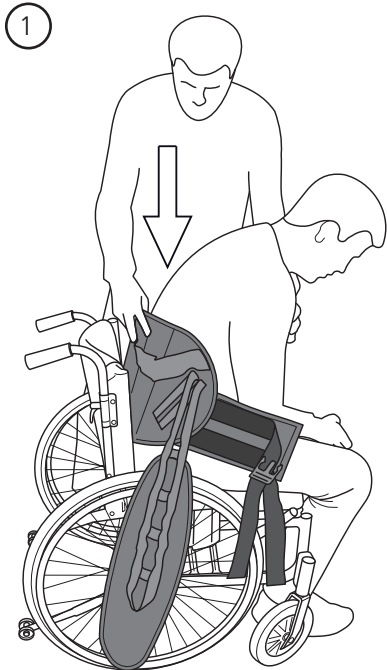

B1. Bereid de gebruiker voor door zijn/haar onderkleding los te maken. Houd de sling met de ene hand vast en gebruik de andere om de patiënt te ondersteunen. Schuif de sling achter de rug van de gebruiker. Plaats de sling aan de rugzijde ongeveer op taillehoogte.

B2. Bevestig de gordel en haal hem aan. Controleer of de onderkleding van de patiënt toegankelijk is.

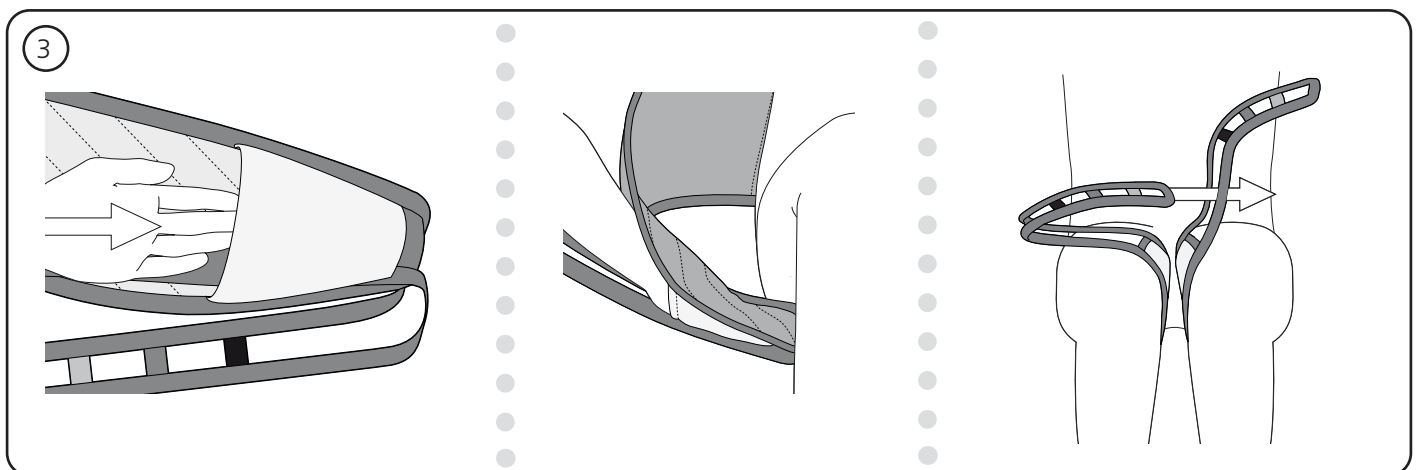

B3. Plaats de beensteunen onder de dijnen van de patiënt. De pocket aan de buitenzijde van de beensteun vereenvoudigt het aanbrengen. Kruis de beenlussen door een van de lussen door de andere te trekken.

Tillen

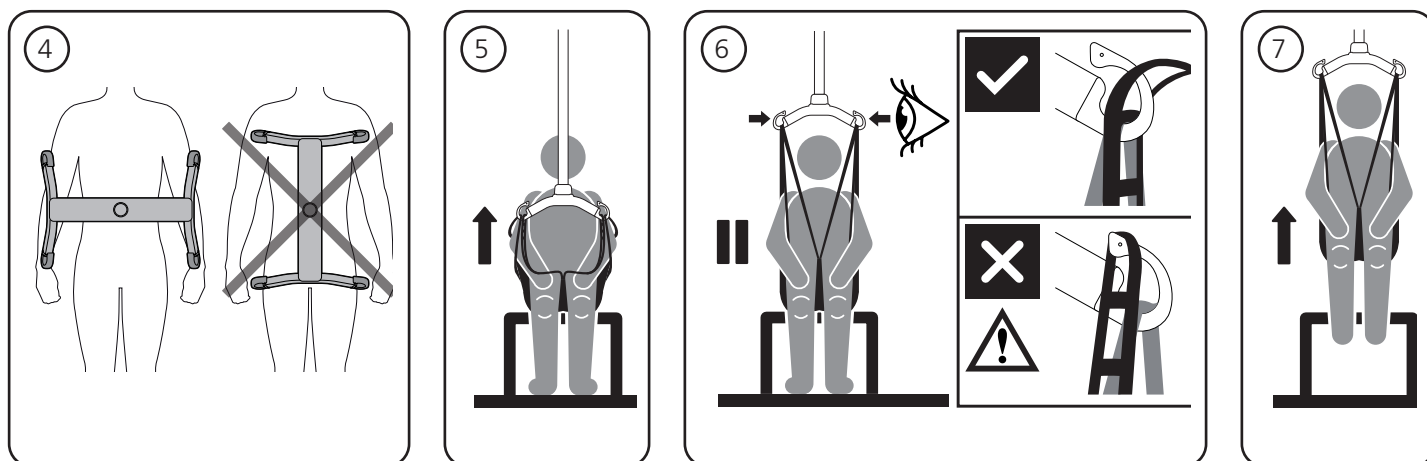

- B4. De slingstang moet altijd tegenover de gebruiker worden geplaatst, zodat de gebruiker niet uit de sling kan glijden.
 B5. Bevestig de sling aan de haken van de slingstang.
 B6. Haal omhoog tot de lussen strak staan, maar til de gebruiker nog niet op. Controleer of

- de gebruiker goed in de sling is geplaatst en of de bandlussen op de juiste wijze aan de slingstanghaken zijn bevestigd.
 B7. Til de gebruiker niet hoger dan noodzakelijk is. Vergeet niet dat de wielen op een mobiele lift NIET vergrendeld moeten zijn.

In zitpositie laten zakken

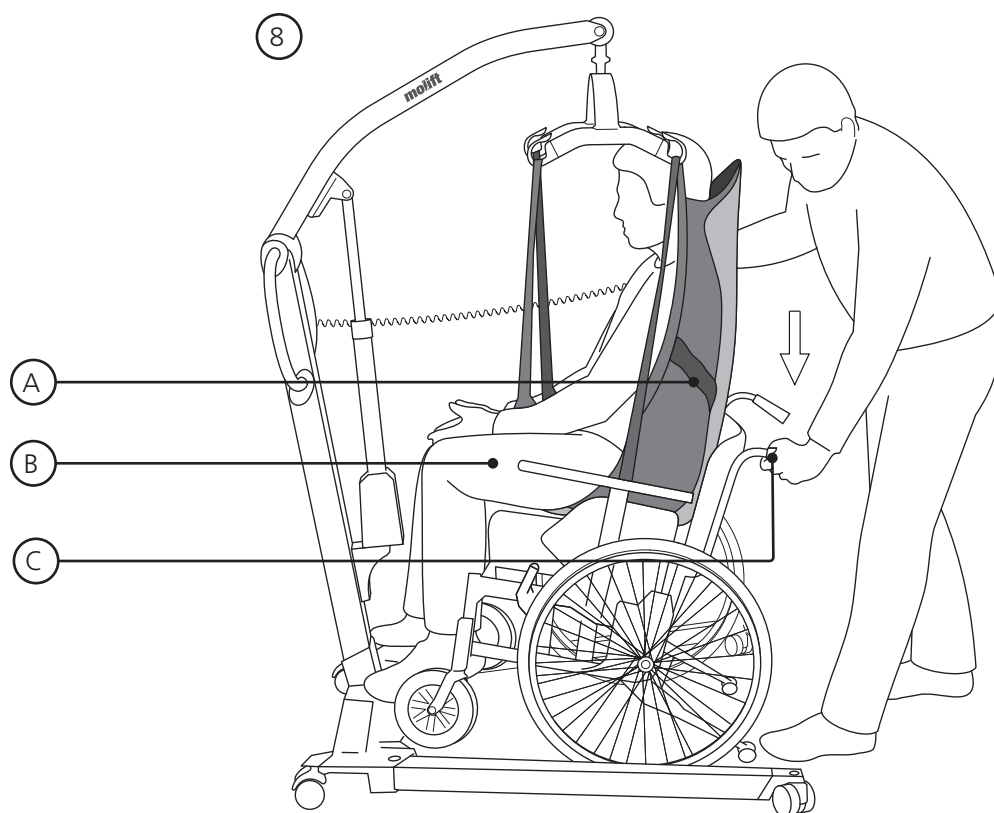

- B8. Bij het verplaatsen van de gebruiker naar een zittende positie, kunt u hem/haar met de volgende technieken zo ver mogelijk naar achteren plaatsen:

- A. Plaats de gebruiker met behulp van de geleiderhandgreep.
 B. Duw voorzichtig tegen de knieën van de gebruiker.
 C. Kantel de zitting naar achteren.

C

Sling verstellen en controlepunten

RgoSling Toilet LowBack

- C1. Zorg dat de ophanging niet het gezicht van de gebruiker raakt.
- C2. Gordel bevestigd en aangehaald.
- C3. Kruis de ophanglussen.
- C4. Beensteun correct geplaatst
- C5. Rugsteun op juiste hoogte geplaatst

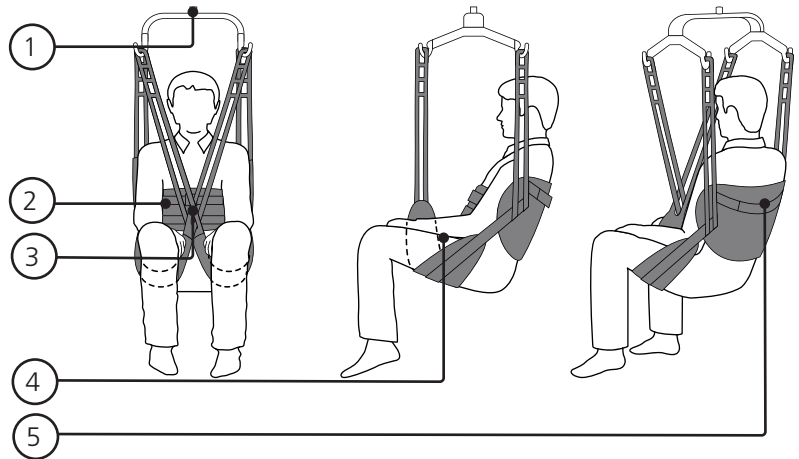

RgoSling Toilet High-

- C6. Zorg dat de ophanging niet het gezicht van de gebruiker raakt.
- C7. Gordel bevestigd en aangehaald.
- C8. Kruis de ophanglussen.
- C9. Beensteun correct geplaatst
- C10. Rugsteun op juiste hoogte geplaatst
- C11. Verstelen hoofdstleun

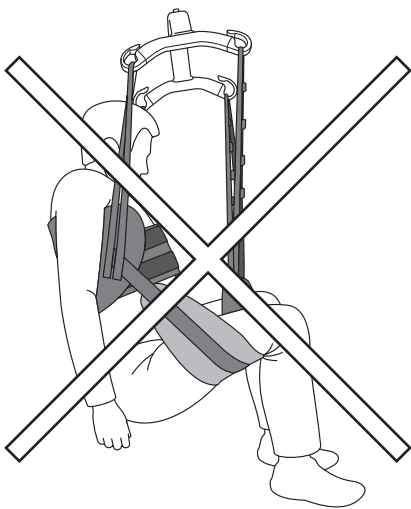
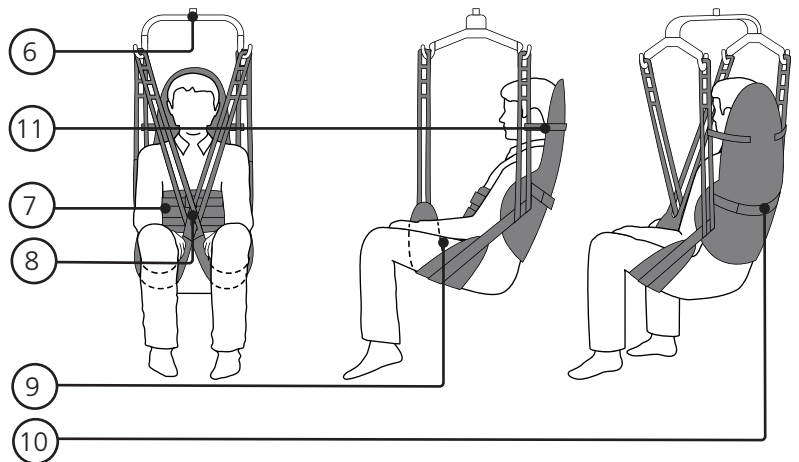

C12. Onjuiste plaatsing van de sling. Het rugdeel is te hoog geplaatst en de beensteunen zijn te ver naar voren geplaatst. Die situatie kan zich voordoen bij gebruikers met een lage spierspanning.

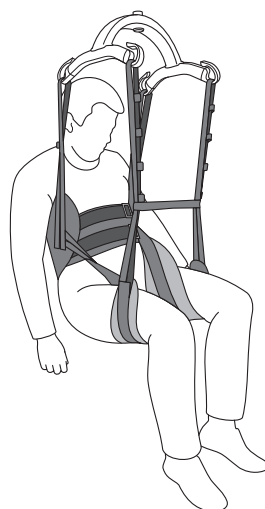

C13. Alternatieve plaatsing van beensteunen met extra verlenglussen.

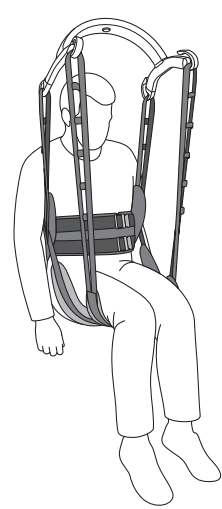

C14. Alternatieve plaatsing van beensteun, met beide beensteunen onder beide benen

D

Sling verwijderen

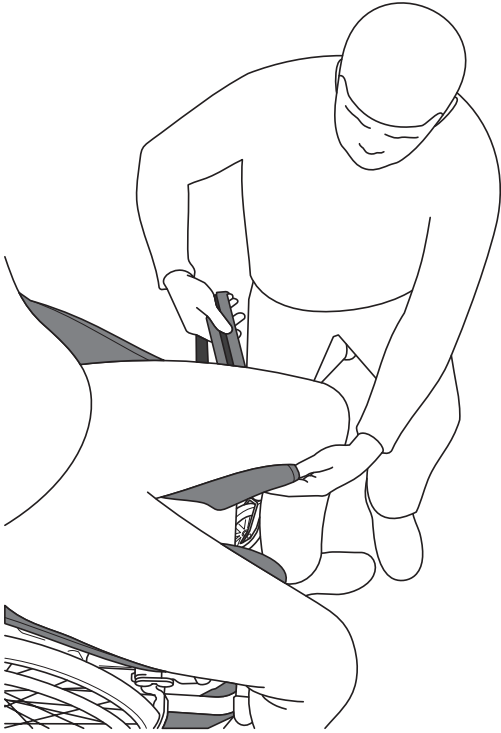



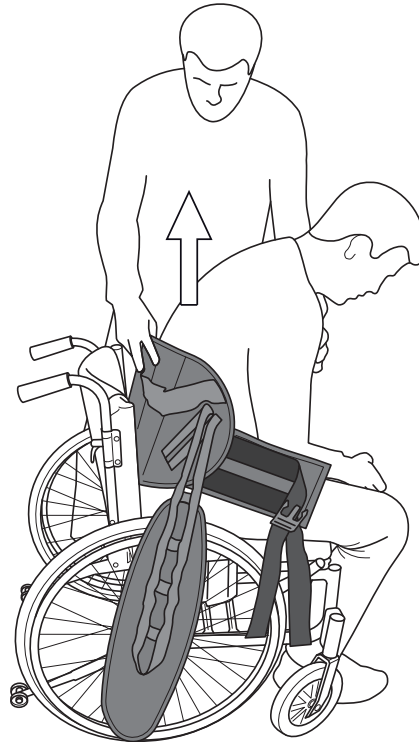





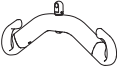



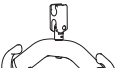
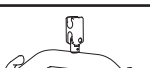
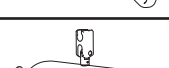
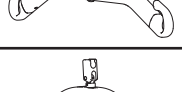

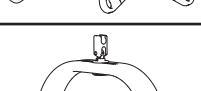
D1. Verwijder de beensteun door hem onder de sling en de dijen van de gebruiker te vouwen en naar voren te trekken.

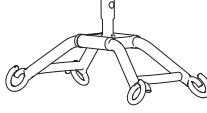
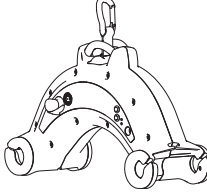

D2. Ga bij de stoel staan en laat de gebruiker naar voren leunen, terwijl u hem/haar met één hand ondersteunt. Trek de sling met de andere hand weg en zet de gebruiker weer tegen de rugleuning aan. Door te hard aan de sling te trekken, kan de gebruiker naar voren vallen en letsel oplopen. Houd de gebruiker altijd met één hand vast.

Combinatielijst

Suspension		RgoSling Toilet Lowback / RgoSling Toilet Highback		
		XXS - S	S - L	L - XXL
Mover 180				
	2-pt Small	✓		
	2-pt Medium	✓	✓	
	2-pt Large		✓	
	4-pt Medium	✓	✓	✓
	4-pt Large		✓	✓
Mover 205				
	2-pt Small	✓		
	2-pt Medium	✓	✓	
	2-pt Large		✓	
	4-pt Medium	✓	✓	✓
	4-pt Large		✓	✓
Mover 300				
	4-pt Medium	✓	✓	✓
	4-pt Large		✓	✓
Partner 255				
	4-pt Medium	✓	✓	✓
	4-pt Large		✓	✓

Suspension		RgoSling Toilet Lowback / RgoSling Toilet Highback		
		XXS - XS	S - L	XL - XXL
Smart				
	4-pt Medium	✓	✓	✓
Nomad				
	4-pt Medium	✓	✓	✓
Nova				
	2-pt Small	✓		
	2-pt Medium	✓	✓	
	2-pt Large		✓	
	4-pt Medium		✓	✓
	4-pt Large			✓

Handleiding sling

De te selecteren maat hangt deels af van het gewicht, functie en lichaamsomtrek/omvang van de gebruiker. De veilige werkbelasting (SWL) is 300 kg.

Afmetingen	Gewicht (Kg)
XXL	230-300
XL	160-240
L	90-160
M	45-95
S	25-50
XS	17-25
XXS	12-17

Problemen oplossen

Probleem	Mogelijke oorzaak/oplossing
De gebruiker past niet goed in de sling.	Verkeerde slingmaat. Probeer een andere maat.
	De sling is te klein als de beensteunen niet tot halverwege de binnenkant van de dijen reiken en de ophanging te dicht bij het gezicht van de gebruiker is. Probeer een andere maat.
	De sling is niet goed aangebracht. Trek de sling bij het aanbrengen bij de rug goed naar beneden.
Het gewicht wordt niet gelijktijdig over alle banden verdeeld.	Wordt het gewicht niet evenredig over de sling verdeeld, dan kan hij aan de rugzijde omhoog-glijden, zodat de gebruiker naar de opening van de sling zakt. Zorg dat de beensteunen op de juiste wijze op de dijen zijn geplaatst.
De gebruiker glijdt door/uit de sling.	De sling is niet goed afgesteld voor deze specifieke gebruiker.
	De gebruiker draagt gladde kleding. Vervang de betreffende kledingstukken of verwijder ze.

EN

SV

NO

DA

FI

DE

NL

FR

IT

ES

Manuel français

Table des matières

Généralités.....	74
Test et garantie	74
Consignes de sécurité.....	75
Inspection.....	75
Inspection périodique	75
Description.....	76
Etac Molift RgoSling Toilet LowBack	76
Etac Molift RgoSling Toilet HighBack	76
Entretien/nettoyage	76
Application du harnais.....	78
Levage	79
Installation en position assise	79
Réglage du harnais et points de vérification	80
Retrait du harnais en position assise	81
Liste des associations.....	82
Guide des harnais.....	82
Dépannage	82

Test et garantie

CE Ce produit est marqué CE.

Les harnais Etac Molift sont testés par des organismes agréés et respectent les normes définies dans la Directive sur les dispositifs médicaux de classe 1 MDR (EU) 2017/745. Les harnais sont conformes aux exigences spécifiées dans la norme EN ISO 10535.

Garantie : deux ans pour tout défaut matériel ou de fabrication en cas d'utilisation correcte.

Pour en savoir plus sur la gamme de harnais et de lève-personnes Etac Molift, consultez le site www.molift.com

Généralités

Merci d'avoir choisi un harnais Molift Etac.

Lisez attentivement ce manuel afin d'éviter tout dommage lorsque vous manipulez et utilisez ce produit.

Dans ce manuel, l'« utilisateur » désigne la personne soulevée. L'« assistant » est la personne actionnant le harnais.



Dans ce manuel, ce symbole s'accompagne d'un texte. Il attire l'attention sur les risques pour la sécurité de l'utilisateur ou de l'assistant.

Etac améliore en permanence ses produits. Nous nous réservons donc le droit de les modifier sans préavis.



Rendez-vous sur www.molift.com pour obtenir des informations, des conseils et les mises à jour des documents.

Nous ne saurions être tenus pour responsables des erreurs d'impression ou des omissions.

Consignes de sécurité



Lisez attentivement le manuel du harnais et du lève-personne avant d'utiliser ces dispositifs afin d'éviter toute blessure lors de la manipulation et de l'utilisation de ces produits.



Ne rangez pas le harnais à la lumière directe du soleil.

Inspection périodique

Une inspection périodique doit être réalisée au moins tous les 6 mois. Des inspections plus régulières peuvent s'avérer nécessaires si le harnais est utilisé ou nettoyé plus souvent que la normale. Consultez le formulaire des inspections périodiques sur le site www.molift.com.

Il est important que le harnais soit testé avec chaque utilisateur et pour le levage prévu. Décidez du nombre d'assistants nécessaires.

Planifiez l'opération de levage en avance afin de garantir une procédure aussi sûre et en douceur que possible. Pensez à adopter une position de travail ergonomique.

Évaluez les risques et prenez des notes. En tant que soignant, vous êtes responsable de la sécurité de l'utilisateur.



Ne soulevez jamais l'utilisateur plus haut que nécessaire pour procéder au levage. Ne laissez jamais un utilisateur sans surveillance au cours d'un levage.



Vérifiez toujours que l'utilisateur présente la capacité nécessaire pour le harnais choisi.that the user has the required ability for the sling in question

- Le modèle, la taille et le matériel doivent être adaptés.
- Le harnais doit convenir au lève-personne ou à la suspension utilisé.
- Il convient de vérifier que les boucles des sangles sont correctement fixées sur les crochets de la suspension avant de lever l'utilisateur.
- Assurez-vous que les roues du fauteuil roulant, du lit ou de la couchette sont bloquées lorsque c'est nécessaire pendant la procédure de transfert.

Inspection

Inspectez régulièrement le harnais, de préférence avant chaque opération de levage et en particulier après le nettoyage.

- Vérifiez l'absence d'usure ou de dommages au niveau des coutures, du tissu, des sangles et des boucles.



N'utilisez jamais de harnais défectueux ou endommagé qui risquerait de se déchirer ou de provoquer des blessures. Détruisez et jetez les harnais endommagés ou usés.

EN

SV

NO

DA

FI

DE

NL

FR

IT

ES

Description

Etac Molift propose une grande variété de harnais convenant à divers types de transfert. L'Etac Molift RgoSling a été conçu pour offrir un rapport poids/charge uniforme afin de le rendre le plus confortable possible..

Une poignée guide permet d'installer les utilisateurs dans la position assise qui convient, uniquement en mode levage. La gamme de harnais Etac Molift RgoSling a été développée pour être associée à une barre de harnais à 4 points mais le harnais fonctionne également avec une barre à 2 points. Reportez-vous à la liste des associations adéquates de harnais et de barres.

La gamme de harnais pour les toilettes Molift RgoSling Toilet est disponible en tailles XXS à XXL, en polyester matelassé..

Etac Molift RgoSling Toilet LowBack

Le harnais pour les toilettes Etac Molift RgoSling Toilet LowBack est muni d'un empiècement bas dans le dos et d'un support de jambes séparé à ouverture large. Le harnais peut servir au levage depuis ou vers la position assise.

Etac Molift RgoSling Toilet HighBack

Le harnais pour les toilettes Molift RgoSling Toilet HighBack est muni d'un empiècement haut pour le dos et d'un support de jambes séparé à ouverture moyenne. Le harnais comporte un repose-tête. Le harnais peut servir au levage depuis ou vers la position assise.

Les harnais pour les toilettes RgoSling Toilet LowBack et RgoSling Toilet HighBack ne conviennent pas aux personnes à faible tonus musculaire. Les patients présentant un faible tonus musculaire risquent de glisser du harnais, ce dernier étant doté d'une ouverture large.

Ce produit présente une durée de vie de 1 à 5 ans dans des conditions normales d'utilisation. Sa durée de vie dépend de la fréquence d'utilisation, des matières, des charges et de la fréquence de nettoyage.

- A1. Étiquette du produit
- A2. (01) EAN-code
xxxxxxxxxxxxxxxx
- (21) Numéro de série
xxxxxxx
- A3. Code QR
- A4. Étiquette : Inspection périodique
- A5. Étiquette : Nom de l'utilisateur
- A6. Boucle de sangle supérieure
- A7. Ceinture
- A8. Rembourrage
- A9. Poignée guide, côté
- A10. Poignée guide, dos
- A11. Réglage du repose-tête
- A12. Support de jambes
- A13. Poche d'application, jambe
- A14. Boucles de sangle inférieure
- A15. Repose-tête
- A16. Symbole : Lisez le manuel avant utilisation
- A17. Symbole : Poids max. de l'utilisateur
- A18. Symbole : Ce côté du produit est orienté vers le haut et vers l'extérieur
- A19. Symbole : Encart pour plus d'informations

Entretien/nettoyage

Lisez les consignes d'entretien disponibles sur le produit.

1. Les harnais lavables à l'eau peuvent être nettoyés à des températures comprises entre 60 et 85 °C.
2. Séchage en tambour, max. 45 °C. Peut être autoclavé à 85 degrés pendant 30 minutes
3. Ne pas laver à sec.
4. Ne pas passer à la javel.
5. Ne pas repasser.



Lavée à des températures élevées, la matière s'use plus vite.

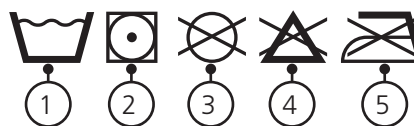

Symboles:



Fabricant



Date de fabrication.
AAAA-MM-DD
(année/mois/jour)



Marquage CE



Consultez le manuel d'utilisation



Vers le haut,
côté extérieur



max 255 kg / max 560 lbs
Poids max. de l'utilisateur :



Dispositif médical

B

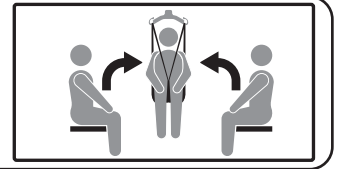

Application du harnais

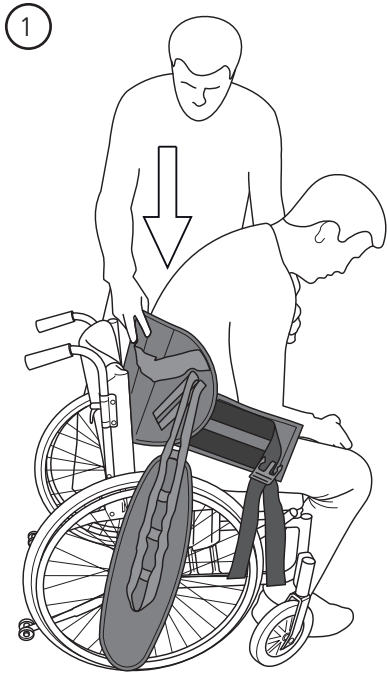

B1. Préparez l'utilisateur en débouonnant son pantalon. Tenez le harnais avec une main et utilisez l'autre main pour maintenir le patient. Faites glisser le harnais dans le dos de l'utilisateur. Placez le harnais au niveau de la taille dans le dos.



B2. Fixez la ceinture et serrez-la. Assurez-vous que le pantalon est accessible.

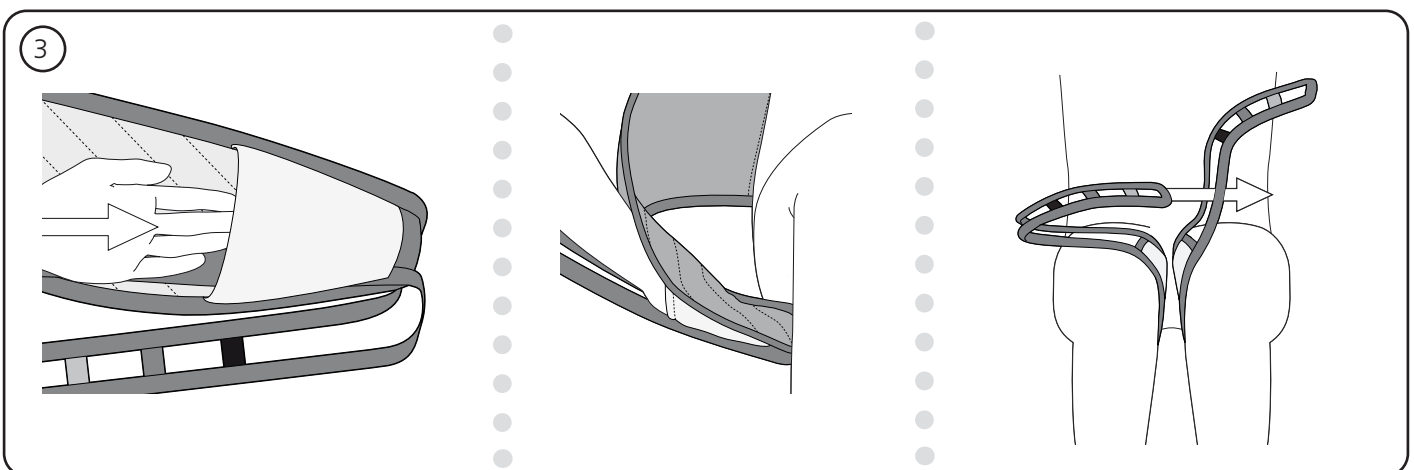

B3. Placez les supports de jambes sous les cuisses de l'utilisateur. La poche située à l'extrémité extérieure du support de jambes facilite l'application. Croisez les boucles de jambes en tirant l'une des boucles dans l'autre.

Levage

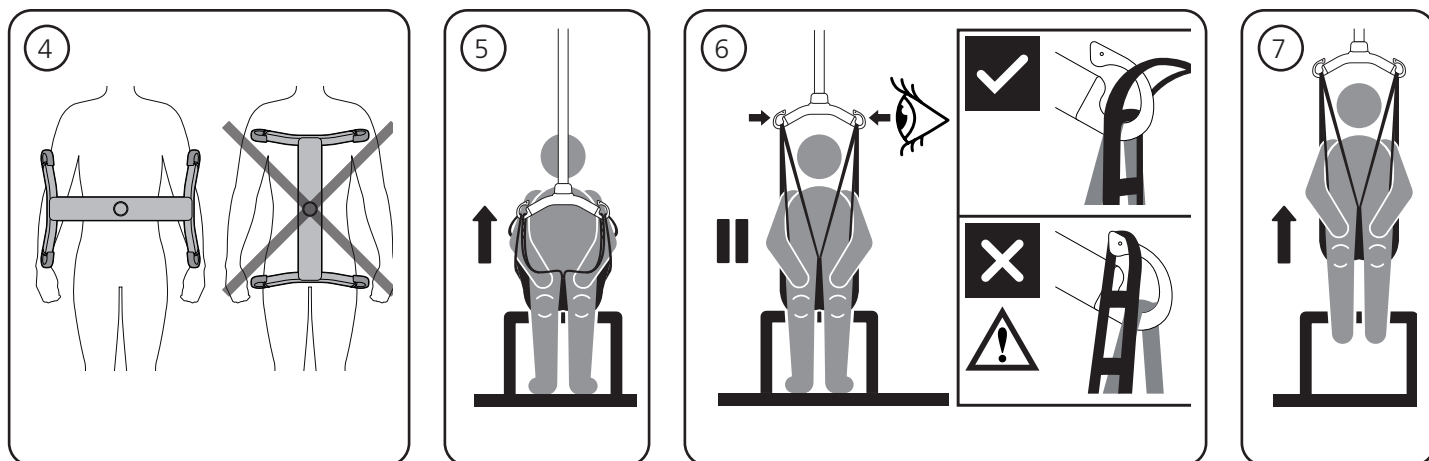

- B4. La barre de harnais doit toujours être positionnée dans la largeur de l'utilisateur afin d'éviter qu'il ne glisse accidentellement du harnais.
- B5. Accrochez le harnais aux crochets de la barre.
- B6. Étirez les sangles du harnais sans soulever l'utilisateur. Vérifiez que le harnais soutient correctement l'utilisateur et que les boucles des

- sangles sont correctement fixées aux crochets de la barre.
- B7. Ne soulevez jamais l'utilisateur plus que nécessaire. Rappelez-vous que les roues du lève-personne mobile NE doivent PAS être bloquées.

Installation en position assise

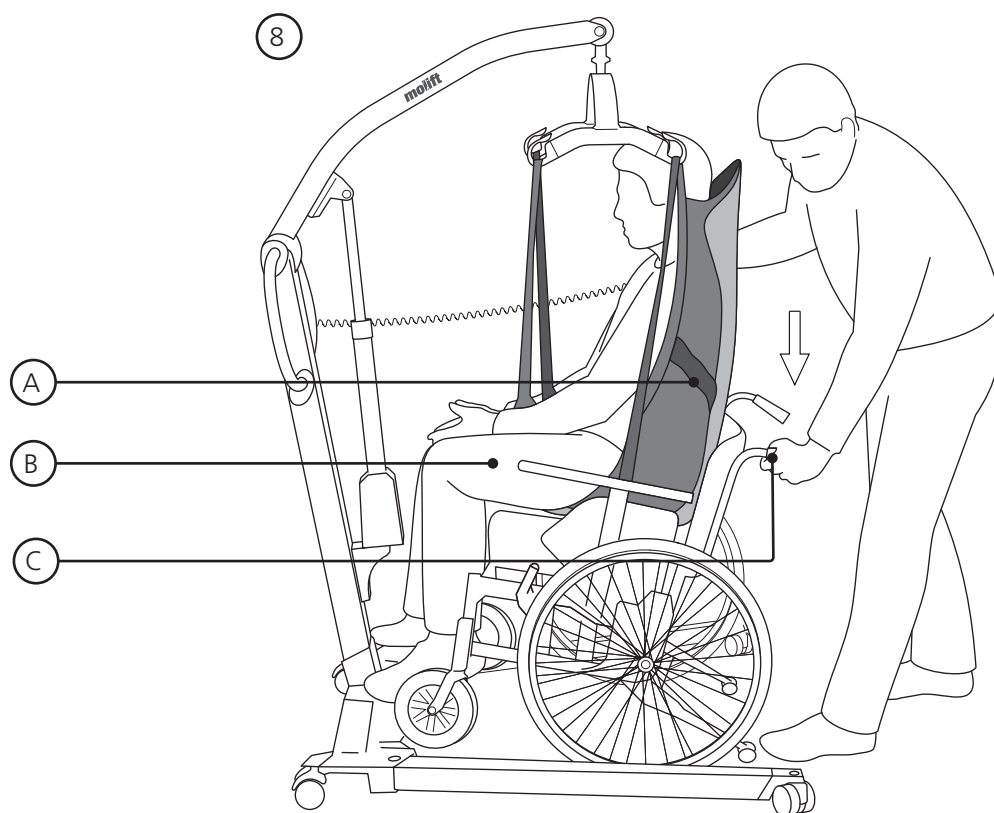

- B8. Lors du transfert de l'utilisateur en position assise, les techniques suivantes peuvent être utilisées pour faire descendre l'utilisateur en lui maintenant le dos le plus près possible du fauteuil :

- A. Installez l'utilisateur à l'aide de la poignée de commande
- B. Appuyez doucement sur les genoux de l'utilisateur
- C. Inclinez le siège vers l'arrière

C

Réglage du harnais et points de vérification

RgoSling Toilet LowBack

- C1. Vérifiez que la suspension se trouve loin du visage de l'utilisateur
- C2. Ceinture à la taille verrouillée et serrée
- C3. Croisez les boucles de suspension
- C4. Support de jambes correctement placé
- C5. Dossier réglé à la bonne hauteur

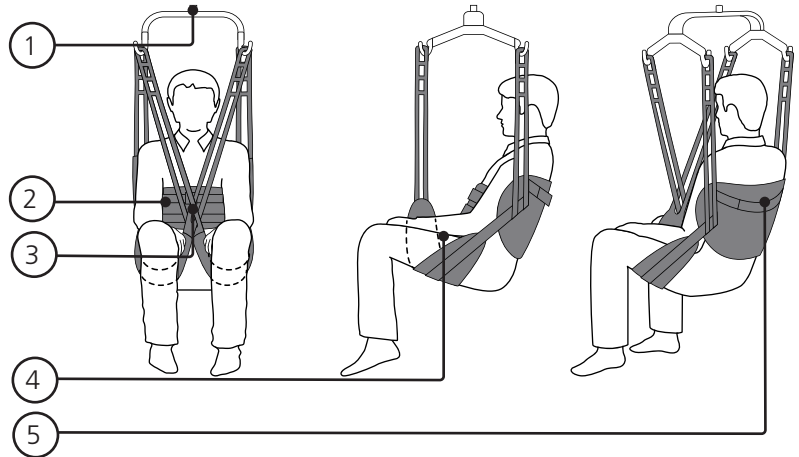

RgoSling Toilet High-

- C6. Vérifiez que la suspension se trouve loin du visage de l'utilisateur
- C7. Ceinture à la taille verrouillée et serrée
- C8. Croisez les boucles de suspension
- C9. Support de jambes correctement placé
- C10. Dossier réglé à la bonne hauteur
- C11. Réglage du repose-tête

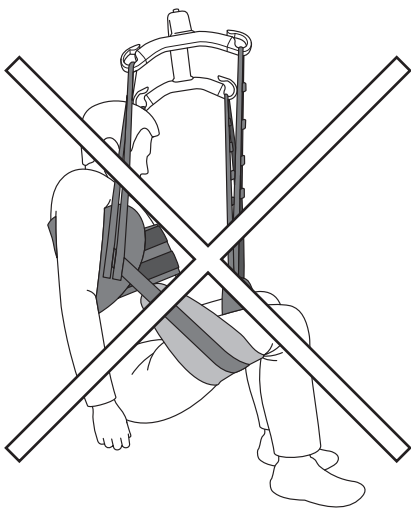
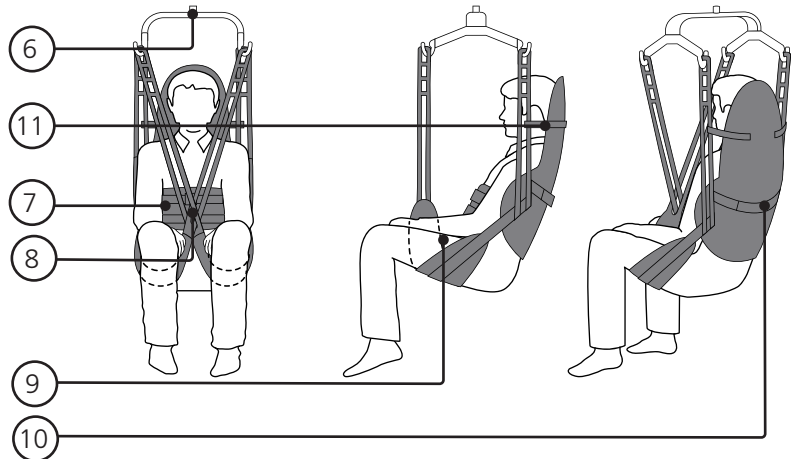

C12. Harnais mal positionné. L'empêchement dorsal et le support de jambes sont installés trop en avant. Cette situation peut également se produire si l'utilisateur présente un faible tonus musculaire.

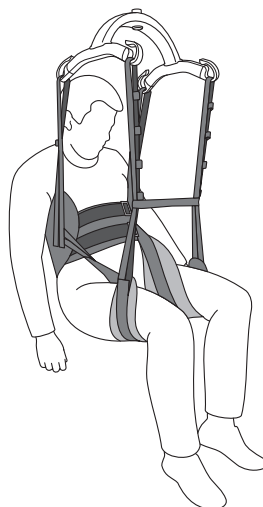

C13. Il existe une autre solution pour l'installation du support de jambes : les extensions de boucles en supplément.

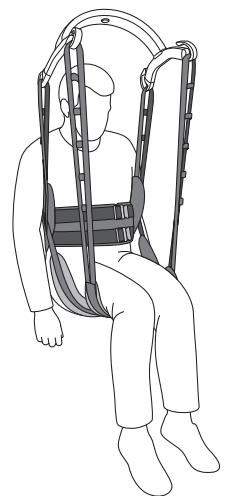

C14. Il existe une autre solution pour l'installation du support de jambes : les supports de jambes peuvent être placés sous les deux jambes.

D

Retrait du harnais en position assise

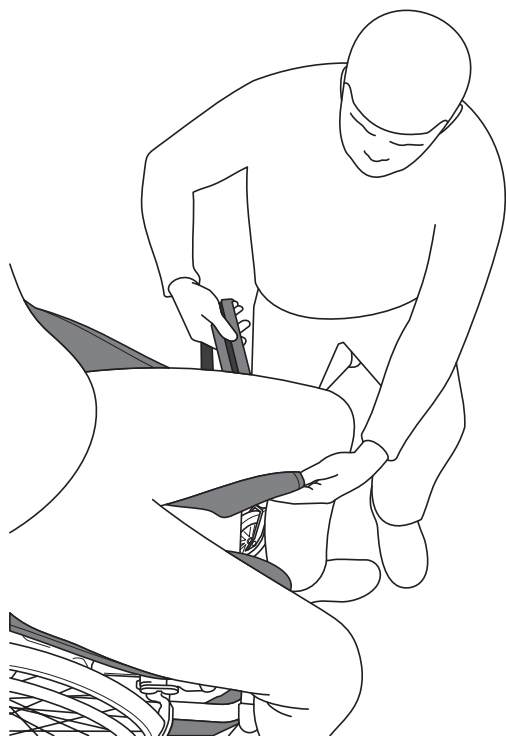



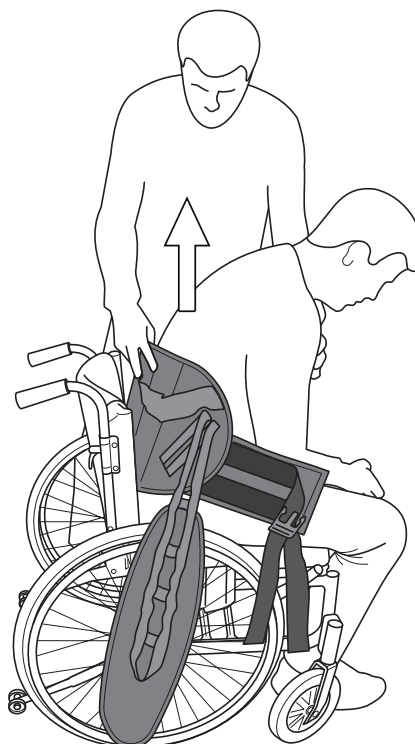









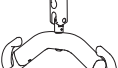
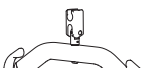
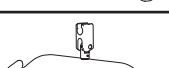

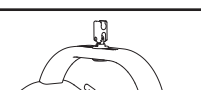

D1. Retirez le support de jambes en le repliant sous le harnais directement et sous les cuisses de l'utilisateur puis tirez dessus.

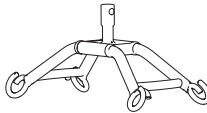
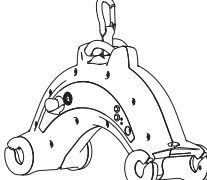

D2. Restez debout près de la chaise et penchez l'utilisateur vers l'avant tout en le soutenant avec une main. Retirez le harnais avec l'autre main et replacez l'utilisateur vers l'arrière dans la chaise. Si vous remontez trop le harnais, l'utilisateur risque de basculer vers l'avant et se blesser. Maintenez toujours une main autour de l'utilisateur.

Liste des associations

Suspension		RgoSling Toilet Lowback / RgoSling Toilet Highback		
		XXS - S	S - L	L - XXL
Mover 180				
	2-pt Small	✓		
	2-pt Medium	✓	✓	
	2-pt Large		✓	
	4-pt Medium	✓	✓	✓
	4-pt Large		✓	✓
Mover 205				
	2-pt Small	✓		
	2-pt Medium	✓	✓	
	2-pt Large		✓	
	4-pt Medium	✓	✓	✓
	4-pt Large		✓	✓
Mover 300				
	4-pt Medium	✓	✓	✓
	4-pt Large		✓	✓
Partner 255				
	4-pt Medium	✓	✓	✓
	4-pt Large		✓	✓

Suspension		RgoSling Toilet Lowback / RgoSling Toilet Highback		
		XXS - XS	S - L	XL - XXL
Smart				
	4-pt Medium	✓	✓	✓
Nomad				
	4-pt Medium	✓	✓	✓
Nova				
	2-pt Small	✓		
	2-pt Medium	✓	✓	
	2-pt Large		✓	
	4-pt Medium		✓	✓
	4-pt Large			✓

Guide des harnais

La taille dépend en partie du poids de l'utilisateur, de l'utilisation et de la circonférence corporelle de l'utilisateur. La CMU (charge maximale d'utilisation) est de 300 kg.

Taille	Poids (Kg)
XXL	230-300
XL	160-240
L	90-160
M	45-95
S	25-50
XS	17-25
XXS	12-17

Dépannage

Problème	Cause/mesure possible
Toutes les sangles ne se soulèvent pas en même temps.	Taille de harnais incorrecte. Essayez une autre taille.
	Le harnais est trop petit lorsque les supports de jambes n'atteignent pas la moitié de la cuisse intérieure et lorsque la suspension est trop proche du visage de l'utilisateur. Essayez une autre taille.
	Le harnais n'est pas correctement installé. Placez le harnais assez bas dans le dos lors de sa mise en place.
Toutes les sangles ne se soulèvent pas en même temps.	Si les sangles du harnais se soulèvent de façon déséquilibrée, cela signifie que le harnais peut remonter derrière, ce qui risque de faire glisser l'utilisateur dans l'ouverture du harnais. Vérifiez que les supports de jambes sont correctement positionnés sur les cuisses.
L'utilisateur glisse à travers le harnais.	Le harnais n'est pas correctement raccordé selon l'ordonnance individuelle.
	L'utilisateur porte des vêtements glissants. Changez ou retirez ces vêtements.

EN

SV

NO

DA

FI

DE

NL

FR

IT

ES

Manuale italiano

Indice

Cenni generali	84
Test e garanzia	84
Precauzioni di sicurezza	85
Ispezione	85
Ispezione periodica	85
Descrizione	86
Etac Molift RgoSling Toilet LowBack	86
Etac Molift RgoSling Toilet HighBack	86
Pulizia/lavaggio	86
Applicazione dell'imbragatura	88
Sollevamento da posizione seduta	89
Abbassamento in posizione seduta	89
Regolazione dell'imbragatura e punti di controllo	90
Rimozione dell'imbragatura	91
Elenco di possibili combinazioni	92
Guida dell'imbragatura	92
Risoluzione dei problemi	93

Descrizione

Grazie per aver scelto un'imbragatura della gamma Molift di Etac.

Per evitare danni durante la manipolazione e l'utilizzo del prodotto è necessario leggere attentamente questo manuale.

In questo manuale, il termine "utente" è riferito alla persona che viene sollevata.

L'assistente è invece la persona che maneggia l'imbragatura.



Nel manuale questo simbolo compare unitamente a un testo. Indica la necessità di prestare attenzione nei casi di possibili rischi per l'utente o l'assistente.

Etac si impegna a migliorare continuamente i propri prodotti. Ci riserviamo pertanto il diritto di apportare modifiche ai prodotti senza preavviso.



Per maggiori informazioni, suggerimenti e aggiornamenti relativi alla documentazione, visitare il sito www.molift.com.

Si declina qualsiasi responsabilità per eventuali omissioni o errori di stampa.

Test e garanzia

CE Questo prodotto è munito del marchio CE.

Le imbragature Etac Molift sono testate da istituti accreditati e rispondono agli standard definiti nella Direttiva UE sui dispositivi medici 2017/745 per i prodotti di classe 1 (MDR). L'imbragatura soddisfa i requisiti della norma EN ISO 10535.

Garanzia: due anni per difetti di materiale e fabbricazione, a condizione che il prodotto sia correttamente utilizzato.

Maggiori dettagli sulla gamma di imbragature e dispositivi di sollevamento Etac Molift sono disponibili alla pagina www.molift.com.

Precauzioni di sicurezza

Aspetti da osservare



Per evitare infortuni durante la manipolazione e l'utilizzo del prodotto, prima dell'uso è necessario leggere attentamente il manuale per il dispositivo di sollevamento e l'imbragatura.

È importante che l'imbragatura venga testata per lo specifico utente e per le specifiche condizioni a cui quest'ultimo dovrà essere sollevato. È opportuno valutare se sia necessario più di un assistente.

Pianificare anticipatamente l'operazione di sollevamento per garantire che venga eseguita nel modo più agevole e sicuro possibile. Garantire una posizione ergonomica.

Valutare i rischi e prenderne nota. La sicurezza dell'utente è di responsabilità dell'operatore.



Non sollevare mai un utente più in alto di quanto sia necessario per eseguire l'operazione di sollevamento. Non lasciare mai l'utente solo mentre è sollevato.



Controllare sempre

- che l'utente disponga delle abilità richieste per l'uso dell'imbragatura in questione;
- che il modello, la taglia e il materiale siano idonei;
- che l'imbragatura sia idonea per il dispositivo di sollevamento ovvero per la barra per imbragatura da utilizzare.
- Prima di sollevare l'utente, è importante verificare che i passanti delle cinghie siano correttamente fissati ai ganci della barra per imbragatura.
- Accertarsi che le ruote della sedia a rotelle, del letto o della branda siano all'occorrenza bloccate durante l'operazione di trasferimento.

Ispezione

L'imbragatura deve essere ispezionata regolarmente, se possibile prima di ogni operazione di sollevamento e soprattutto dopo ogni lavaggio. Accertarsi che le cuciture, il tessuto, le cinghie e i passanti non presentino segni di usura.



Per evitare il rischio di rotture o infortuni, non utilizzare mai imbragature difettose o danneggiate. Eliminare le imbragature vecchie e danneggiate.



Non depositare l'imbragatura in un punto direttamente esposto al sole.

Ispezione periodica

Le ispezioni periodiche vanno svolte almeno ogni 6 mesi. Se l'imbragatura è utilizzata o lavata con una frequenza superiore al normale può essere necessario accorciare gli intervalli di ispezione. Consultare il modulo di ispezione periodica disponibile alla pagina www.molift.com.

EN

SV

NO

DA

FI

DE

NL

FR

IT

ES

Descrizione

La gamma Etac Molift offre un'ampia selezione di imbragature per diverse tipologie di trasferimenti. L'imbragatura Molift RgoSling è concepita per distribuire uniformemente il peso e la pressione e massimizzare così il comfort.

È presente un'impugnatura di guida per aiutare a disporre l'utente nella corretta posizione seduta. Questo ausilio è utilizzato solo in fase di sollevamento.

L'imbragatura Molift RgoSling è stata sviluppata per poter essere combinata con una sospensione a 4 punti di fissaggio, ma è ugualmente utilizzabile con una sospensione a 2 punti di fissaggio. Vedere l'elenco di possibili combinazioni per individuare la corretta combinazione tra imbragatura e sospensione.

L'imbragatura Molift RgoSling Toilet è disponibile nelle taglie XXS – XXL in poliestere con imbottitura.

L'imbragatura Etac Molift RgoSling Toilet LowBack

ha lo schienale ribassato ed è munita di un supporto gambe diviso con un'ampia apertura. L'imbragatura può essere utilizzata per sollevare l'utente da o verso la posizione seduta.

L'imbragatura Etac Molift RgoSling Toilet HighBack

ha lo schienale rialzato ed è munita di un supporto gambe diviso di media apertura. Questa imbragatura è provvista di supporto per la testa. L'imbragatura può essere utilizzata per sollevare l'utente da o verso la posizione seduta.

Le imbragature RgoSling Toilet LowBack e RgoSling Toilet HighBack non sono idonee per persone con scarso tono muscolare. Gli utenti con scarso tono muscolare rischierebbe di scivolare fuori dall'imbragatura, essendo questa dotata di un'ampia apertura.

A condizioni d'uso normali, la vita utile prevista del prodotto è compresa tra 1 e 5 anni. La vita utile del prodotto varia a seconda della frequenza d'uso, dei materiali, dei carichi sollevati e della frequenza di lavaggio.

- A1. Etichetta prodotto
- A2. (01) Codice EAN
xxxxxxxxxxxxxxxx
- (21) Numero di serie
xxxxxxxx
- A3. Codice QR
- A4. Etichetta: Ispezione periodica
- A5. Etichetta: Nome utente
- A6. Passante della cinghia superiore
- A7. Cinghia in vita
- A8. Imbottitura
- A9. Impugnatura di guida, lato
- A10. Impugnatura di guida, retro
- A11. Regolazione del supporto per la testa
- A12. Supporto gambe
- A13. Tasca per applicazione, gamba
- A14. Passanti delle cinghie inferiori
- A15. Poggiatesta
- A16. Simbolo: Leggere il manuale prima dell'uso
- A17. Simbolo: Peso massimo dell'utente
- A18. Simbolo: Questo lato del prodotto va girato verso l'alto e verso l'esterno
- A19. Simbolo: Aprire per maggiori informazioni

Pulizia/lavaggio

Leggere le istruzioni per la pulizia riportate sul prodotto.

1. Le imbragature lavabili possono essere lavate a temperature comprese tra 60 e 85° C.



Eventuali lavaggi a temperature superiori accelerano l'usura dei materiali.

2. Asciugatura in asciugatrice, max 45° C. Lavabili in autoclave a 85 gradi per 30 minuti
3. Non lavare a secco.
4. Non candeggiare.
5. Non stirare.

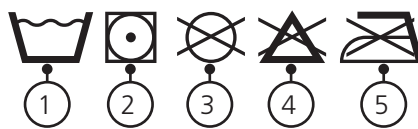

Simboli:



Produttore



Questa parte in alto, questo lato all'esterno



Data di produzione.
AAAA-MM-GG (anno/
mese/giorno)



max 255 kg max 560 lbs
Peso massimo utente



Marcatura CE



Dispositivo medico



Fare riferimento al manuale per l'utente

A

RgoSling Toilet LowBack

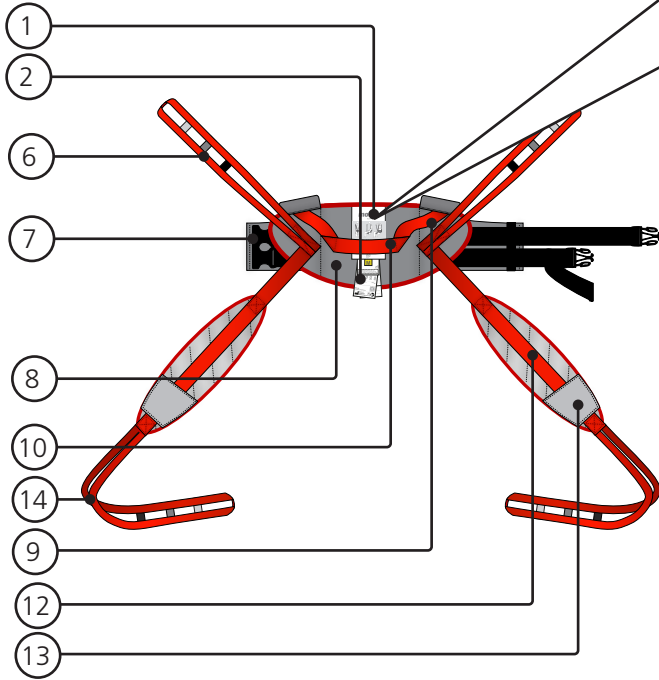

RgoSling Toilet HighBack

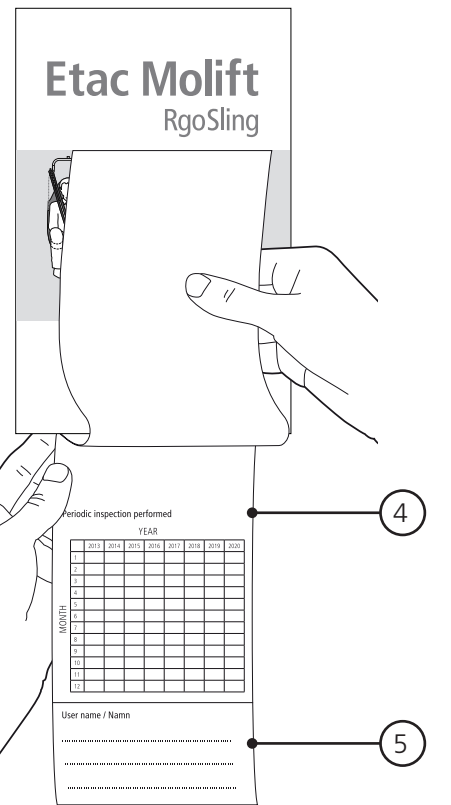
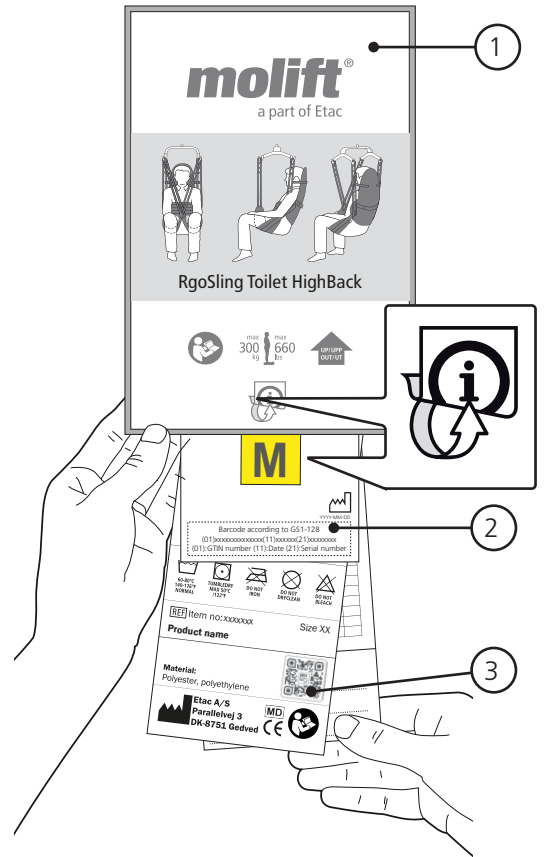
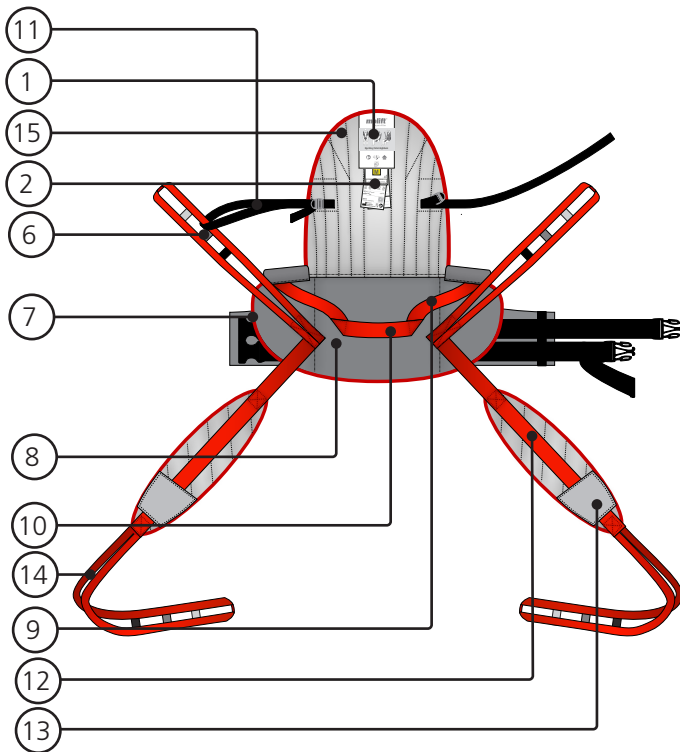

EN SV NO DA FI DE NL FR IT ES

B

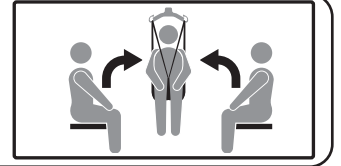

Applicazione dell'imbragatura

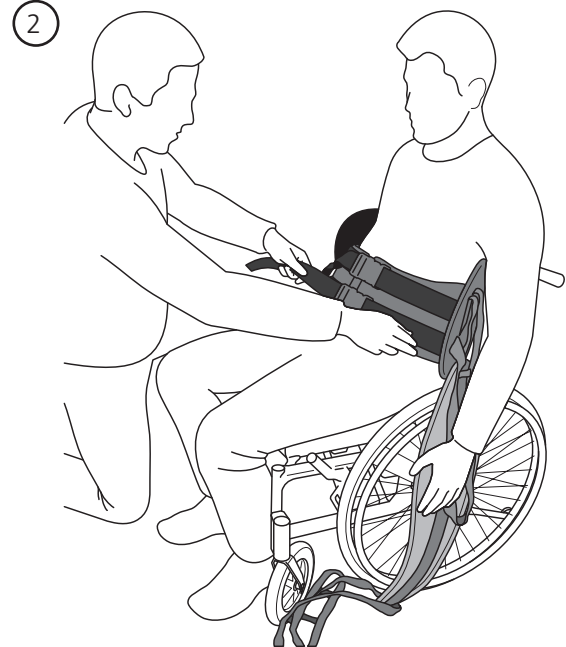
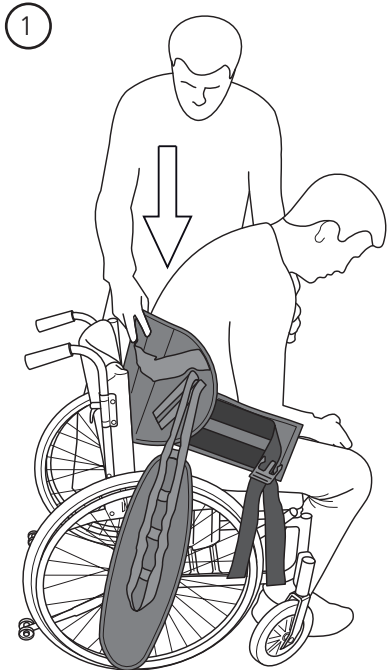

B1. Come operazione preliminare sbottonare i pantaloni dell'utente. Tenere l'imbragatura con una mano e utilizzare l'altra mano per sostenere l'utente. Fare scorrere l'imbragatura verso il basso dietro la schiena dell'utente. Posizionare l'imbragatura all'incirca all'altezza della vita sulla schiena..

B2. Fissare la cinghia in vita e stringere. Accertarsi che i pantaloni rimangano accessibili.

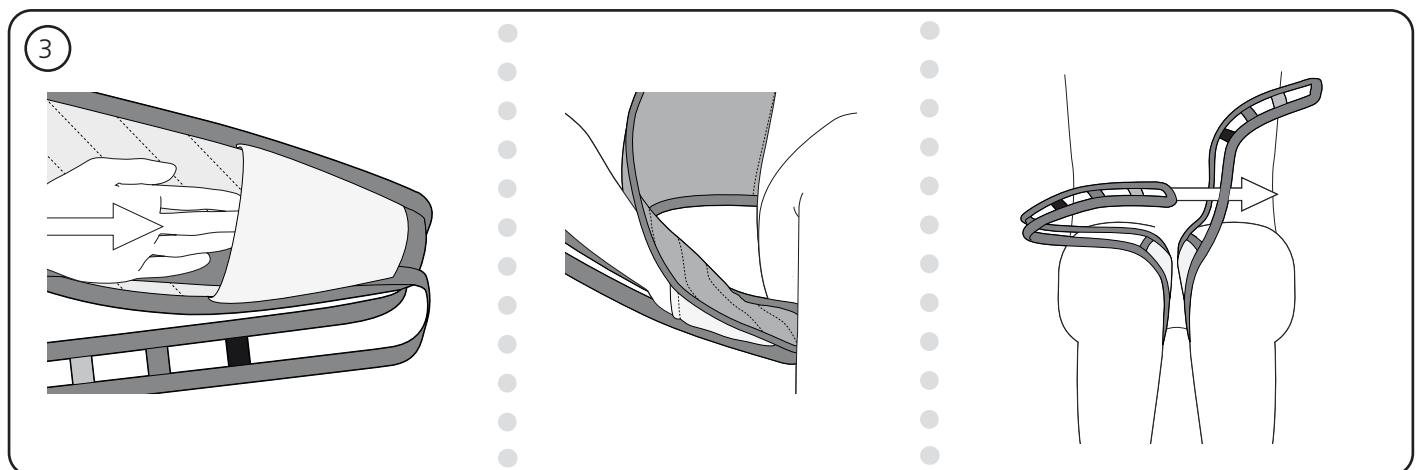

B3. Posizionare il supporto gambe al di sotto delle cosce dell'utente. La tasca sull'estremità esterna del supporto gambe facilita l'applicazione. Incrociare i passanti all'altezza delle gambe tirando l'uno attraverso l'altro.

Sollevamento da posizione seduta

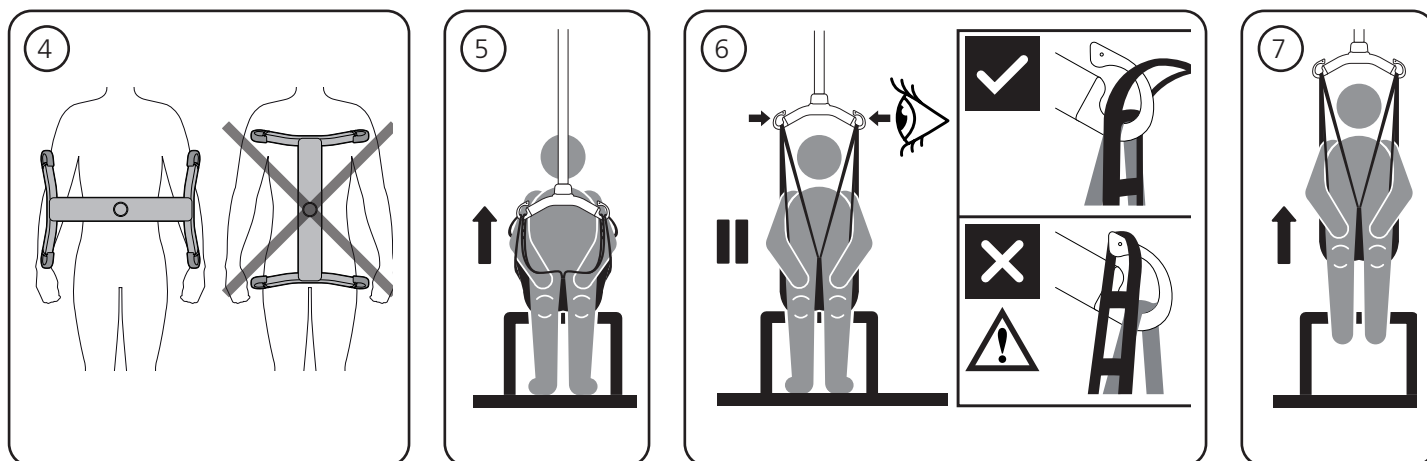

B4. La sospensione deve sempre essere posizionata orizzontalmente, in modo tale da impedire che l'utente scivoli accidentalmente fuori dall'imbragatura.

B5. Assicurare l'imbragatura ai ganci di sospensione.

B6. Tirare le cinghie senza sollevare l'utente. Accertarsi che l'imbragatura sia correttamente

fissata attorno all'utente e che i passanti delle cinghie siano correttamente assicurati ai ganci di sospensione.

B7. Non sollevare l'utente più in alto del necessario. Attenzione: NON bloccare mai le ruote dei dispositivi di sollevamento mobili.

Abbassamento in posizione seduta

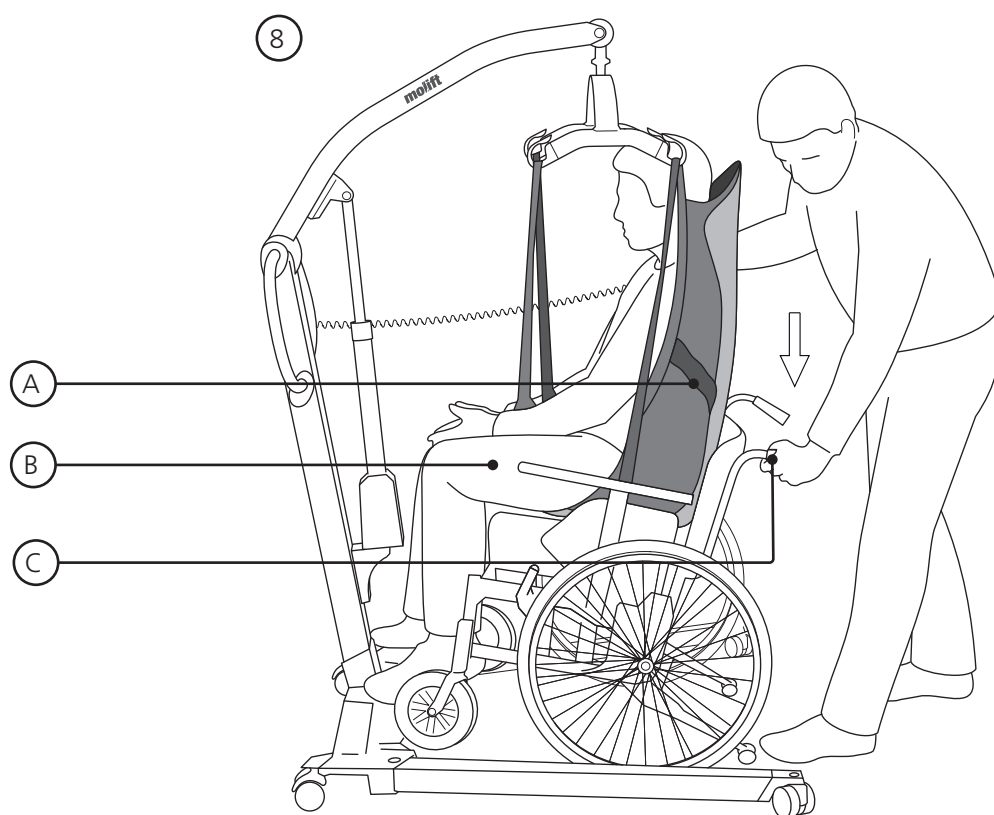

B8. Quando si trasferisce l'utente in posizione seduta, durante l'abbassamento è possibile utilizzare le tecniche seguenti per far sedere l'utente il più indietro possibile:

A. Posizionare l'utente aiutandosi con l'apposita impugnatura

B. Premere delicatamente sulle ginocchia dell'utente

C. Inclinare la sedia all'indietro

C

Regolazione dell'imbragatura e punti di controllo

RgoSling Toilet LowBack

- C1. Accertarsi che la sospensione sia tenuta lontana dal viso dell'utente.
- C2. Cinghia in vita chiusa e stretta.
- C3. Passanti di sospensione incrociati.
- C4. Supporto gambe posizionato correttamente.
- C5. Schienale disposto all'altezza corretta.

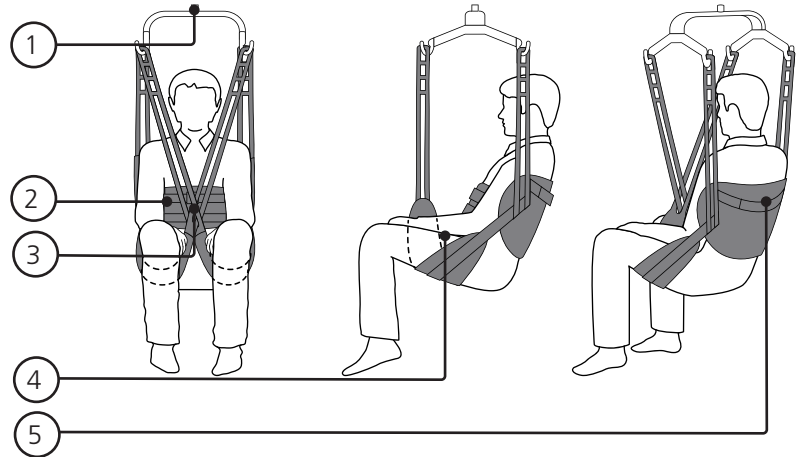

RgoSling Toilet HighBack

- C6. Accertarsi che la sospensione sia tenuta lontana dal viso dell'utente.
- C7. Cinghia in vita chiusa e stretta.
- C8. Passanti di sospensione incrociati.
- C9. Supporto gambe posizionato correttamente.
- C10. Schienale disposto all'altezza corretta.
- C11. Regolazione del supporto per la testa.

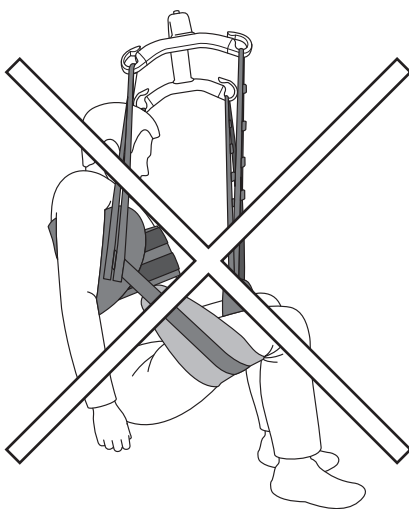
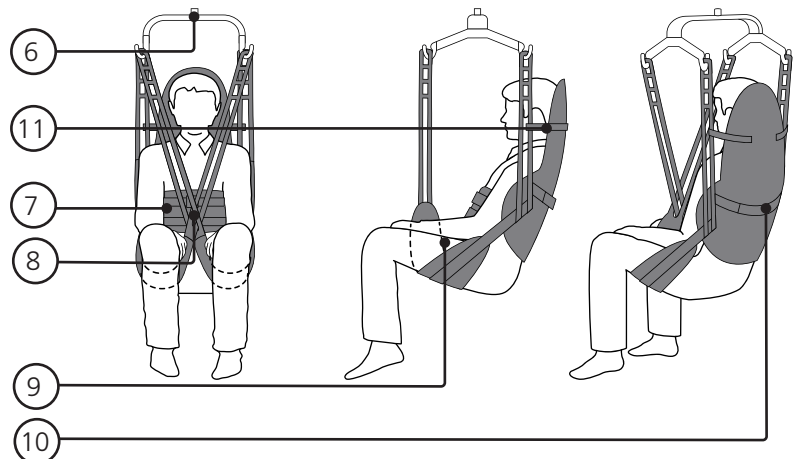

- C12. Posizionamento scorretto dell'imbragatura. Lo schienale è troppo in alto e il supporto gambe troppo in avanti. Questa situazione può verificarsi anche quando l'utente non ha un sufficiente tono muscolare.

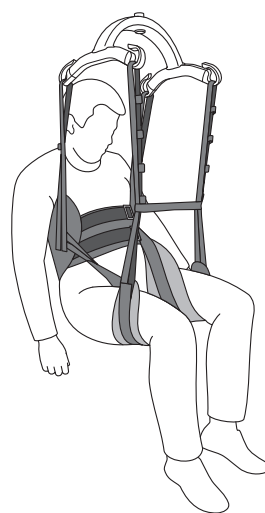

- C13. Disposizione alternativa del supporto gambe mediante i passanti di estensione aggiuntivi.

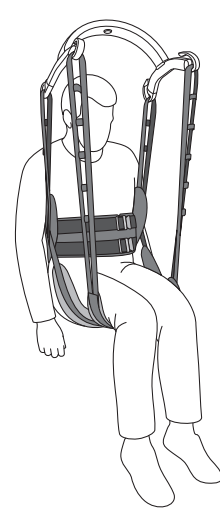

- C14. Disposizione alternativa del supporto gambe con entrambi i supporti sotto entrambe le gambe.

D

Rimozione dell'imbragatura

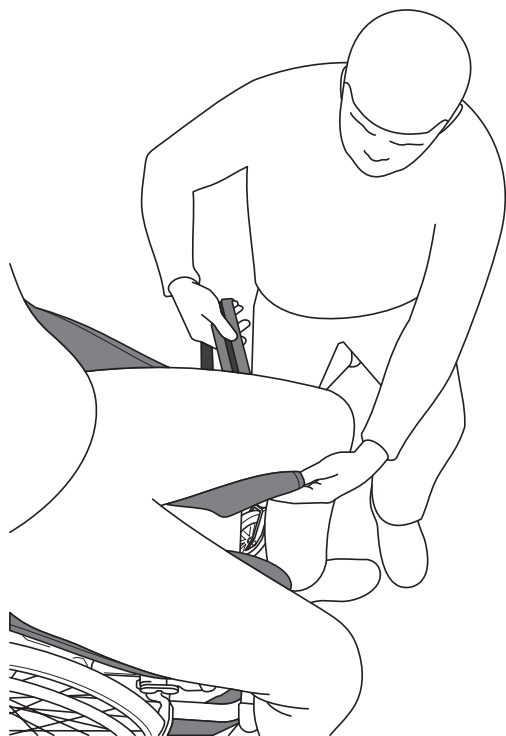



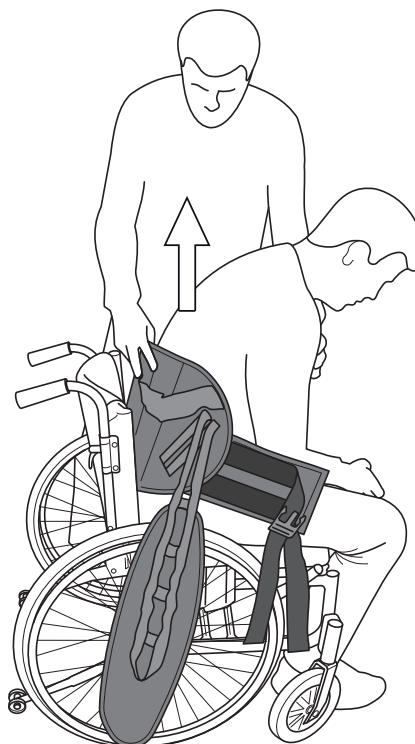







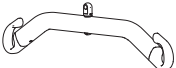

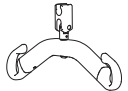
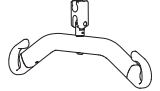
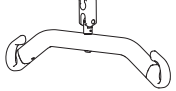
D1. Rimuovere il supporto gambe piegandolo al di sotto della coscia dell'utente ed estraendolo.

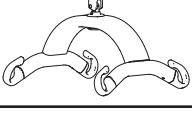

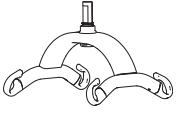
D2. Disporsi di fianco alla sedia e piegare l'utente in avanti sostenendolo con una mano. Togliere l'imbragatura con l'altra mano, quindi fare appoggiare nuovamente l'utente sulla sedia. Se l'imbragatura viene sollevata bruscamente, l'utente rischia di cadere in avanti e infortunarsi. Tenere sempre una mano attorno all'utente.

Elenco delle possibili combinazioni

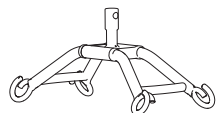
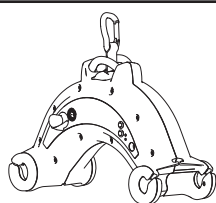
Sospensione		RgoSling Toilet Lowback / RgoSling Toilet Highback		
		XXS - S	S - L	L - XXL
Mover 180				
	2-pt Small	✓		
	2-pt Medium	✓	✓	
	2-pt Large		✓	
	4-pt Medium	✓	✓	✓
	4-pt Large		✓	✓
Mover 205				
	2-pt Small	✓		
	2-pt Medium	✓	✓	
	2-pt Large		✓	
	4-pt Medium	✓	✓	✓
	4-pt Large		✓	✓
Mover 300				
	4-pt Medium	✓	✓	✓
	4-pt Large		✓	✓
Partner 255				
	4-pt Medium	✓	✓	✓
	4-pt Large		✓	✓

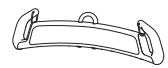
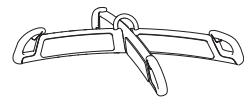
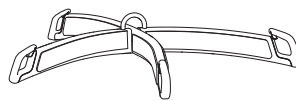
Sospensione		RgoSling Toilet Lowback / RgoSling Toilet Highback		
		XXS - XS	S - L	XL - XXL
Smart				
	4-pt Medium	✓	✓	✓
Nomad				
	4-pt Medium	✓	✓	✓
Nova				
	2-pt Small	✓		
	2-pt Medium	✓	✓	
	2-pt Large		✓	
	4-pt Medium		✓	✓
	4-pt Large			✓

Guida dell'imbragatura

La taglia dipende in parte del peso dell'utente, dalla funzione, dal girovita e dalle dimensioni del corpo.

Carico di lavoro sicuro 300* kg.

Size	Weight (Kg)
XXL	230-300
XL	160-240
L	90-160
M	45-95
S	25-50
XS	17-25
XXS	12-17

Risoluzione dei problemi

Problema	Possibile causa/rimedio
L'utente non riesce a indossare bene l'imbragatura.	La taglia dell'imbragatura non è quella giusta. Provare un'altra taglia
	L'imbragatura è troppo piccola quando i supporti gambe non arrivano alla metà del lato interno della coscia e quando la sospensione è troppo vicina al viso dell'utente. Provare un'altra taglia.
	L'imbragatura non è posizionata correttamente. Tirare l'imbragatura sufficientemente verso il basso lungo la schiena.
Le cinghie non sollevano il carico in maniera uniforme tra loro.	Se le cinghie dell'imbragatura non sollevano il carico in modo uniforme, l'imbragatura rischia di risalire sulla schiena e di far scivolare l'utente attraverso l'apertura. Accertarsi che i supporti gambe siano correttamente posizionati sulle cosce.
L'utente scivola attraverso l'imbragatura o al di fuori di essa.	L'imbragatura non è posizionata in modo conforme ai requisiti specifici.
	L'utente sta indossando abiti troppo scivolosi. Cambiare o togliere parte gli abiti indossati.

EN

SV

NO

DA

FI

DE

NL

FR

IT

ES

Manual en español

Contenido

Recomendaciones generales	94
Prueba y garantía	94
Medidas de seguridad	95
Inspección	95
Inspección periódica	95
Descripción	96
Etac Molift RgoSling Toilet LowBack	96
Etac Molift RgoSling Toilet HighBack	96
Cuidados / lavado	96
Aplicación de la eslinga	98
Elevación.....	99
Descenso del usuario hasta la posición de sentado.....	99
Ajuste de la eslinga y puntos de control .	100
Retirada de la eslinga en posición sentada.....	101
Lista de combinación.....	102
Guía de eslingas	102
Solución de problemas	103

Prueba y garantía

CE de que este producto cuenta con el marcado CE.

Las eslingas Molift de Etac son comprobadas por institutos de ensayos acreditados y cumplen los estándares descritos en la Directiva de productos sanitarios para productos de Clase 1 MDR (EU) 2017/745. Las eslingas cumplen los requisitos especificados en la norma EN ISO 10535.

Garantía: dos años para defectos de material y fabricación con un uso correcto.

Para más detalles sobre la gama de eslingas y grúas Molift de Etac, visite www.molift.com.

Recomendaciones generales

Gracias por haber escogido una eslinga Molift de Etac.

Es necesario leer el manual detenidamente para evitar daños durante el manejo y utilización del producto.

En este manual, se entiende por «usuario» la persona que es elevada. «Asistente» es la persona que opera la eslinga.



Este símbolo aparece en el manual junto con texto. Indica la necesidad de precaución cuando la seguridad del usuario o del asistente pueda estar en riesgo.

Etac realiza continuas mejoras en sus productos. Por esta razón, nos reservamos el derecho de realizar cambios en los productos sin previo aviso.



Visite www.molift.com para obtener más información, consejos y actualizaciones de documentación.

No nos hacemos responsables de errores de imprenta u omisiones.

Medidas de seguridad



Es necesario leer detenidamente el manual tanto para grúas como para eslingas antes de su uso para evitar lesiones durante el manejo y utilización del producto.

Es importante que la eslinga se haya probado con el usuario y para la situación de elevación prevista. Decida si son necesarios uno o más asistentes.

Planifique la elevación de forma anticipada para garantizar que discurre de forma tan segura y fluida como sea posible. Recuerde trabajar de forma ergonómica.

Evalúe los riesgos y tome notas de los mismos. Como cuidador, usted es responsable de la seguridad del usuario.



No eleve nunca a un usuario más de lo necesario por encima del punto de partida para llevar a cabo una elevación. Nunca deje al usuario sin supervisión cuando lo esté elevando



Compruebe siempre que el usuario posee la capacidad necesaria para la eslinga en cuestión

- El modelo, tamaño y material son adecuados
- La eslinga es adecuada para la grúa / percha que se va a utilizar.
- Es importante comprobar que los lazos de las correas están correctamente atados a los ganchos de la percha antes de elevar al usuario.
- Asegúrese de que las ruedas de la silla de ruedas, cama o litera están bloqueadas cuando sea necesario durante el proceso de traslado.

Inspección

La eslinga debe inspeccionarse periódicamente, preferiblemente antes de cada elevación, pero, sobre todo, después de haberse limpiado.

- Compruebe que no hay desgaste ni daños en costuras, tela, correas y lazos.



No utilice nunca una eslinga defectuosa o dañada porque puede romperse y provocar lesiones personales. Destruya y deseche las eslingas viejas y dañadas.



La eslinga no debería guardarse expuesta a la luz solar directa.

Inspección periódica

La inspección periódica debe llevarse a cabo como mínimo cada 6 meses. En ocasiones pueden ser necesarias inspecciones más frecuentes si la eslinga se utiliza o se lava más a menudo de lo habitual. Consulte el formulario de inspección periódica en www.molift.com

Descripción

Molift de Etac ofrece una amplia gama de eslingas para diferentes tipos de traslados. Molift RgoSling de Etac se ha diseñado para ofrecer una relación uniforme entre el peso y la carga lo más cómoda posible.

Hay un asa guía que ayuda a colocar a los usuarios en la posición sentada correcta y se utiliza solo cuando los usuarios se hallan en modo de elevación.

La eslinga Molift RgoSling de Etac se ha desarrollado para combinarse con un percha de 4 puntos pero también funciona con una percha de 2 puntos. Consulte la lista de combinación para la combinación correcta entre eslinga y percha. Molift RgoSling Toilet está disponible en los tamaños XXS – XXL, en poliéster acolchado.

Etac Molift RgoSling Toilet LowBack

Molift RgoSling Toilet LowBack de Etac cuenta con un respaldo bajo y un soporte de la extremidad partido con una apertura ancha. La eslinga puede usarse para elevar al usuario a una posición sentada o desde una posición sentada.

Etac Molift RgoSling Toilet HighBack

Molift RgoSling Toilet HighBack de Etac cuenta con un respaldo alto y un soporte de la extremidad partido con una apertura media. La eslinga cuenta con reposacabezas. La eslinga puede usarse para elevar al usuario a una posición sentada o desde una posición sentada.

RgoSling Toilet LowBack y RgoSling Toilet HighBack no son adecuados para personas con tono muscular bajo. Hay un riesgo elevado de que los pacientes con un tono muscular bajo se salgan de la eslinga, ya que esta cuenta con una apertura ancha.

El producto tiene una vida útil prevista de 1 a 5 años en condiciones de uso normales. La vida útil del producto depende de la frecuencia de uso, de los materiales, de las cargas y de la frecuencia con la que se lava.

- A1. Etiqueta del producto
- A2. (01) Código EAN
xxxxxxxxxxxxxxxx
- (21) Número de serie
xxxxxxx
- A3. Código QR
- A4. Etiqueta: Inspección periódica
- A5. Etiqueta: Nombre de usuario
- A6. Lazo de correa superior
- A7. Cinturón
- A8. Relleno
- A9. Asa guía, lateral
- A10. Asa guía, respaldo
- A11. Ajuste de reposacabezas
- A12. Soporte de la extremidad
- A13. Bolsillo de aplicación, extremidad
- A14. Lazos de las correas inferiores
- A15. Reposacabezas
- A16. Símbolo: lea el manual antes de su uso
- A17. Símbolo: peso máximo del usuario
- A18. Símbolo: este lado del producto apunta hacia arriba y hacia afuera
- A19. Símbolo: desplegar para más información

Cuidados / lavado

Lea las instrucciones de cuidado del producto.

1. Las eslingas que puedan lavarse con agua deberán lavarse a una temperatura entre 60 y 85 °C.



El lavado a temperaturas más altas desgasta el material más rápidamente.

2. Secado en secadora, máx. 45 °C. Puede esterilizarse en autoclave a 85 °C durante 30 minutos.
3. No lavar en seco
4. No utilizar lejía
5. No planchar.

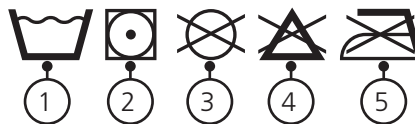

Simboli:



Produttore



Data di produzione.
AAAA-MM-DD
(anno/mese/día)



Marchio CE



Fare riferimento al manuale dell'utente



Lato alto,
lato esterno



max 255 kg max 560 lbs
Peso massimo utente
(carico di sicurezza)



Dispositivo medico

A

RgoSling Toilet LowBack

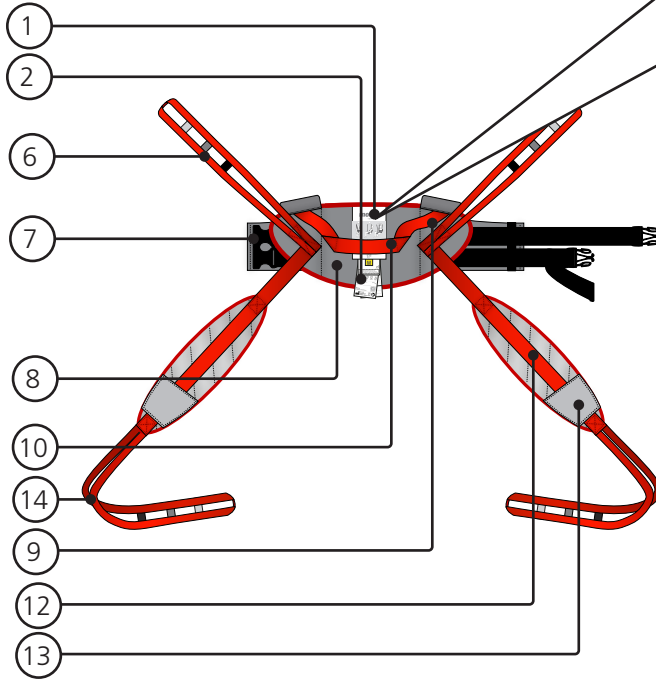

RgoSling Toilet HighBack

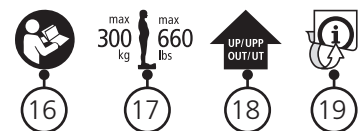
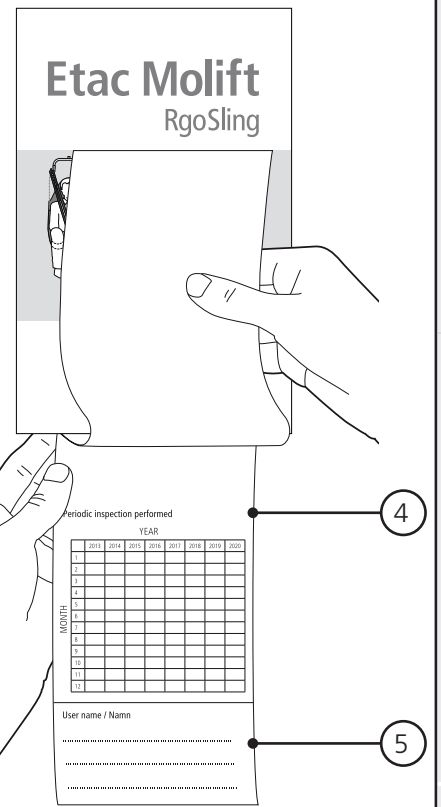
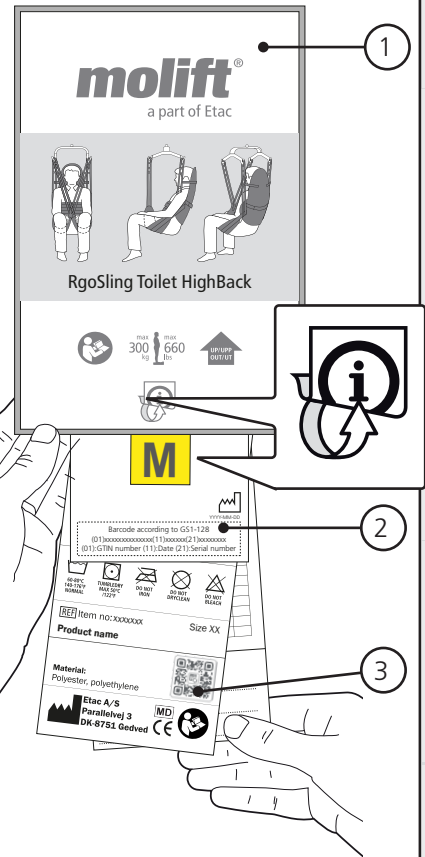
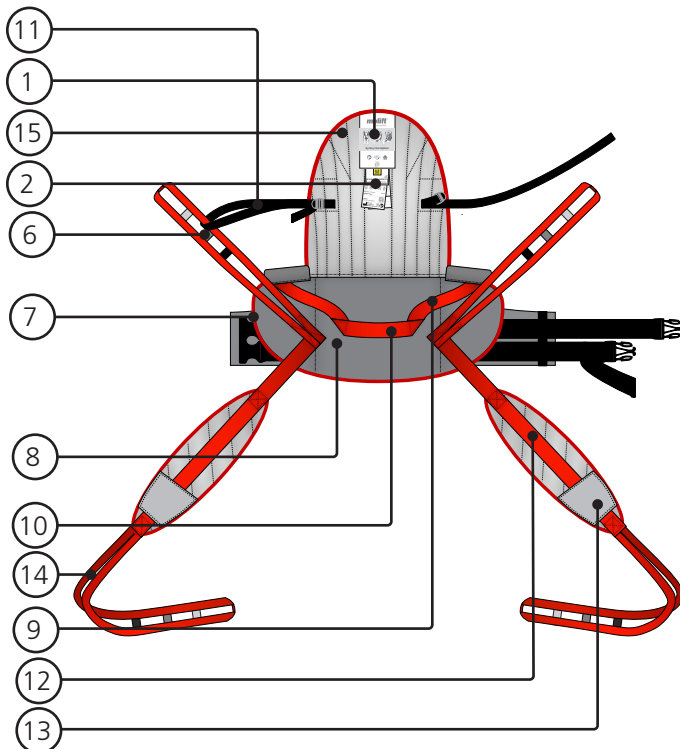

B

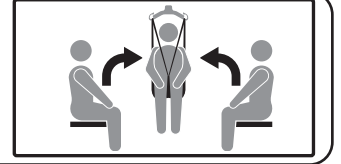

Aplicación de la eslinga

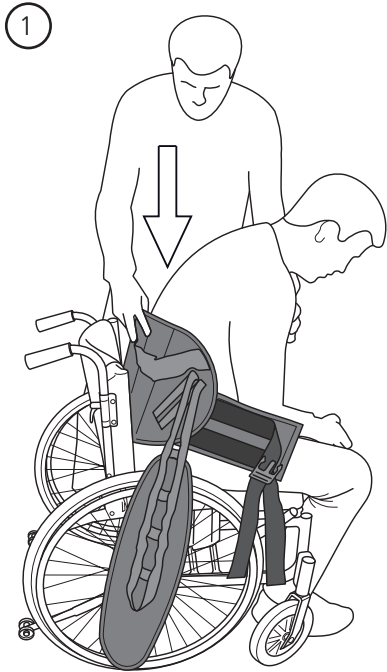

B1. Prepare al usuario desabrochando sus pantalones. Sujete la eslinga con una mano y utilice la otra mano para sujetar al paciente. Deslice la eslinga hacia abajo detrás de la espalda del usuario. Coloque la eslinga aproximadamente a la altura de la cintura en la espalda..

B2. Fije el cinturón y apriételo. Asegúrese de que puede acceder a los pantalones.

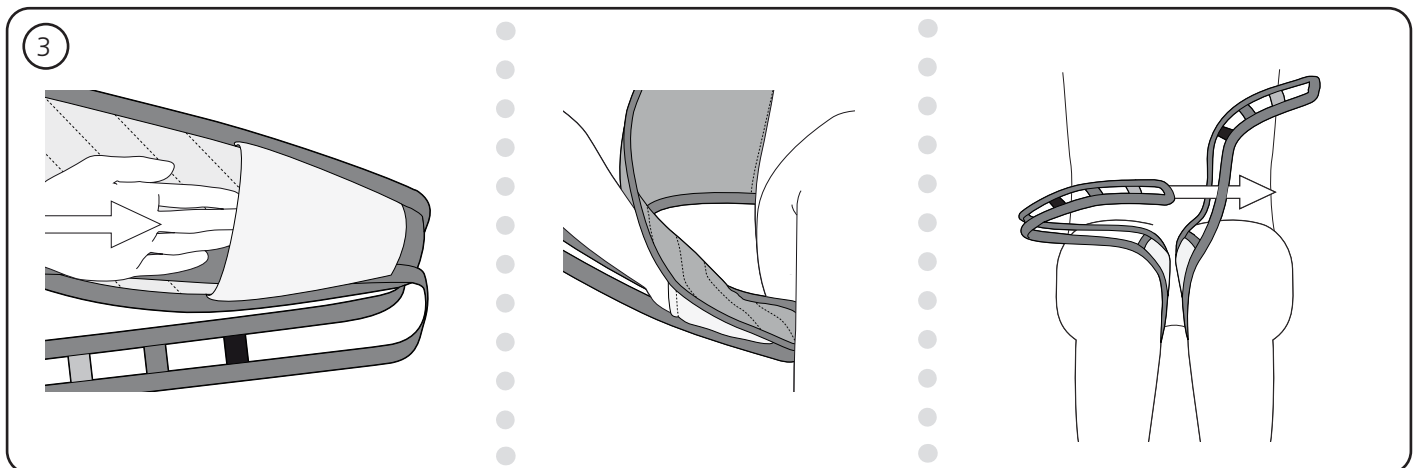

B3. Coloque los soportes de las extremidades debajo de los muslos del usuario. El bolsillo del extremo exterior del soporte de la extremidad facilita la aplicación. Cruce los lazos de las extremidades insertando uno de los lazos a través del otro.

Elevación

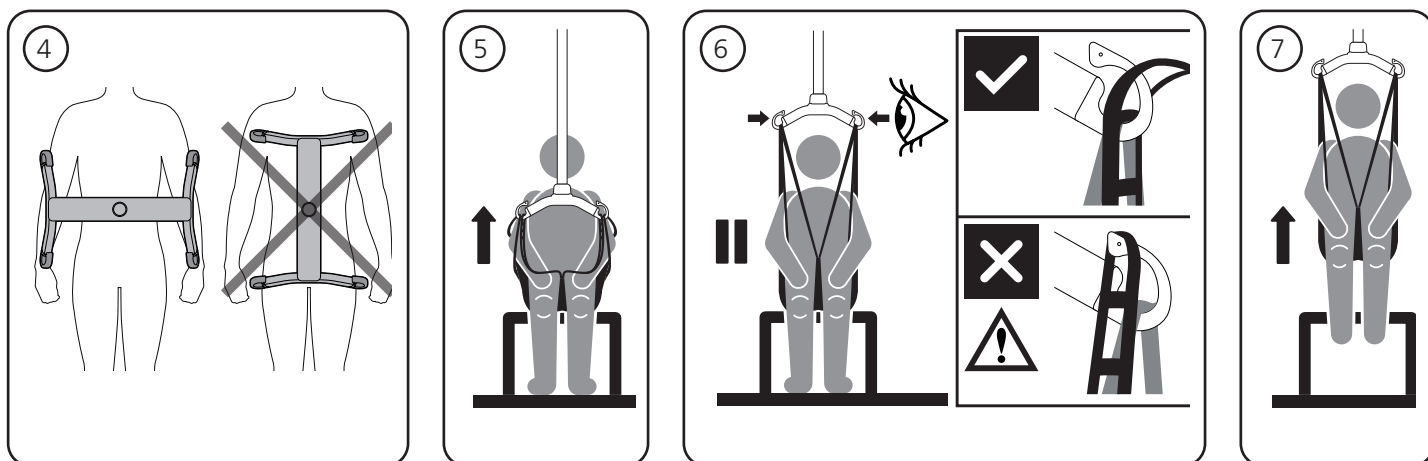

B4. La percha debe colocarse siempre cruzada sobre el usuario para evitar que este se salga accidentalmente de la eslinga.

B5. Suspenda la eslinga en los ganchos de la percha.

B6. Estire las correas de la eslinga sin elevar al usuario. Compruebe que la eslinga está correcta-

mente colocada alrededor del usuario y que los lazos de las correas están correctamente colocados en los ganchos de la percha.

B7. No eleve al usuario más de lo necesario.

Recuerde que las ruedas de una grúa móvil NO deben estar bloqueadas.

Descenso del usuario hasta la posición de sentado

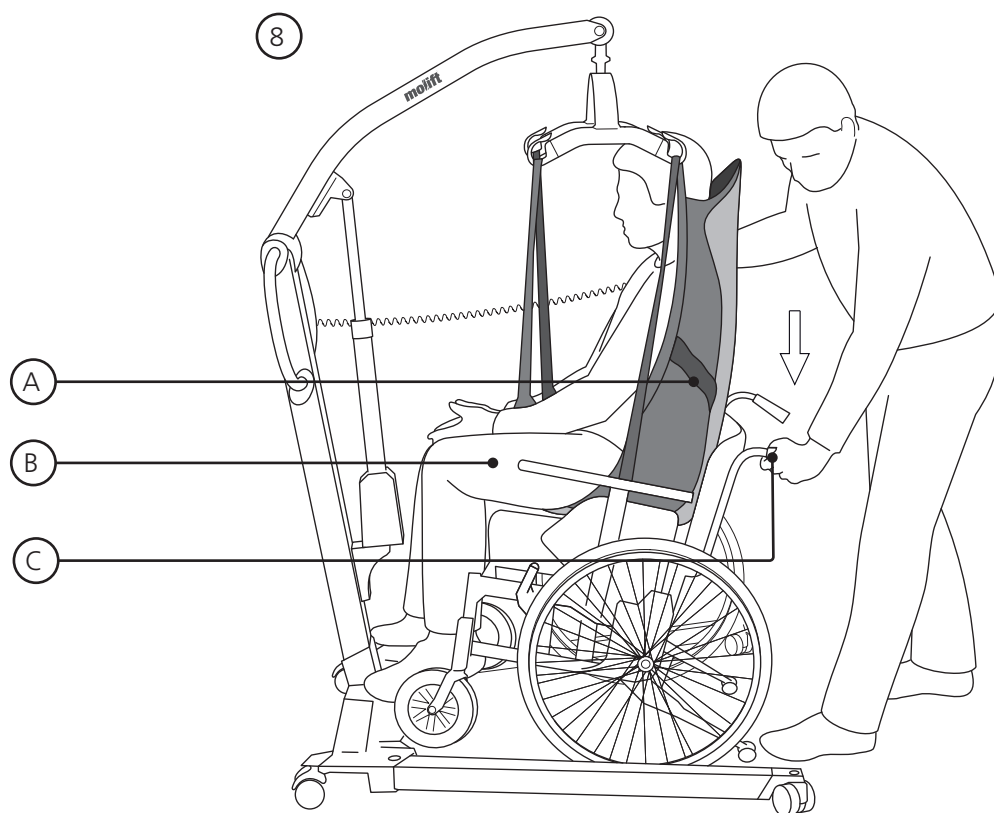

B8. Cuando se traslada el usuario a la posición de sentado, pueden utilizarse las siguientes técnicas cuando se descienda al usuario hacia la parte más posterior del asiento posible:

A. Coloque al usuario ayudándose del asa de dirección.

B. Presione suavemente sobre las rodillas del usuario.

C. Incline el asiento hacia atrás

C

Ajuste de la eslinga y puntos de control

RgoSling Toilet LowBack

- C1. Asegúrese de que la percha está alejada de la cara del usuario.
- C2. Cinturón bloqueado y apretado.
- C3. Cruce los lazos de la percha.
- C4. Soporte de la extremidad colocado correctamente.
- C5. Respaldo colocado a la altura correcta.

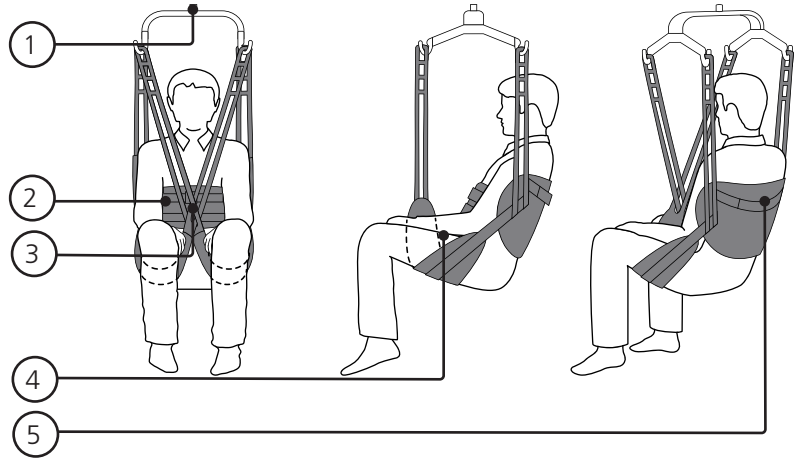

RgoSling Toilet High-

- C6. Asegúrese de que la percha está alejada de la cara del usuario.
- C7. Cinturón bloqueado y apretado.
- C8. Cruce los lazos de la percha.
- C9. Soporte de la extremidad colocado correctamente.
- C10. Respaldo colocado a la altura correcta.
- C11. Ajuste de reposacabezas

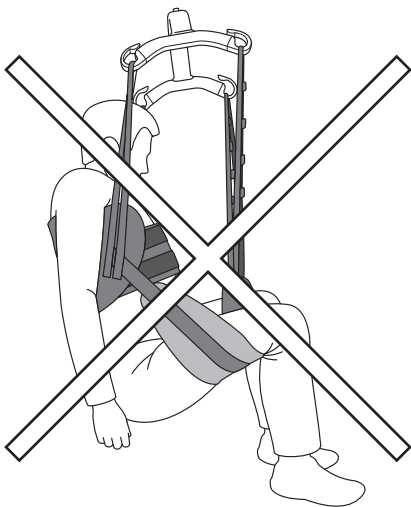
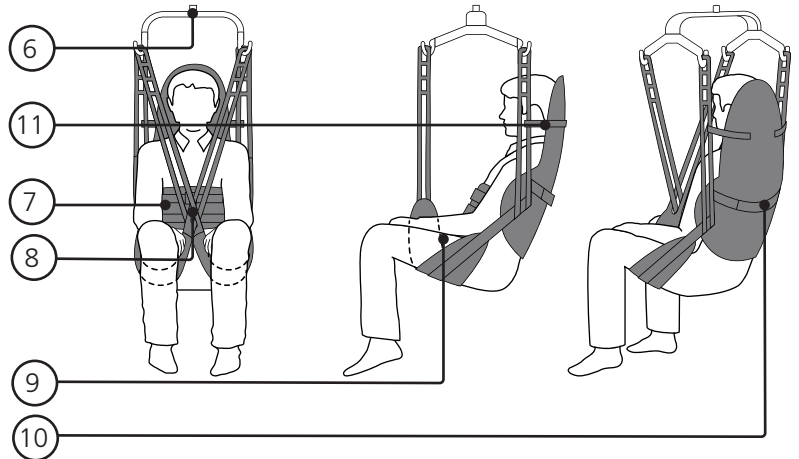

- C12. Posición incorrecta de la eslinga. La pieza posterior está demasiado alta y el soporte de la extremidad demasiado lejos. Esto también puede darse si el usuario no tiene suficiente tono muscular.

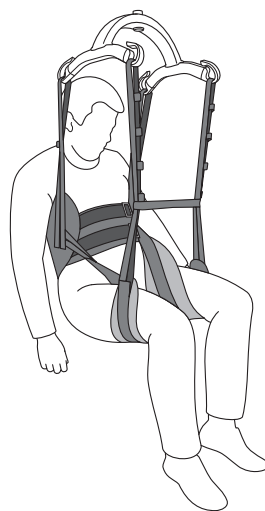

- C13. Colocación del soporte de la extremidad alternativa empleando lazos de extensión adicionales.

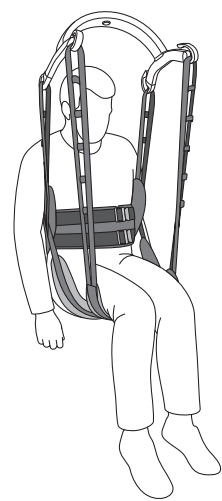

- C14. Colocación del soporte de la extremidad alternativa con ambos soportes de las extremidades bajo las dos piernas.

D

Retirada de la eslinga en posición sentada

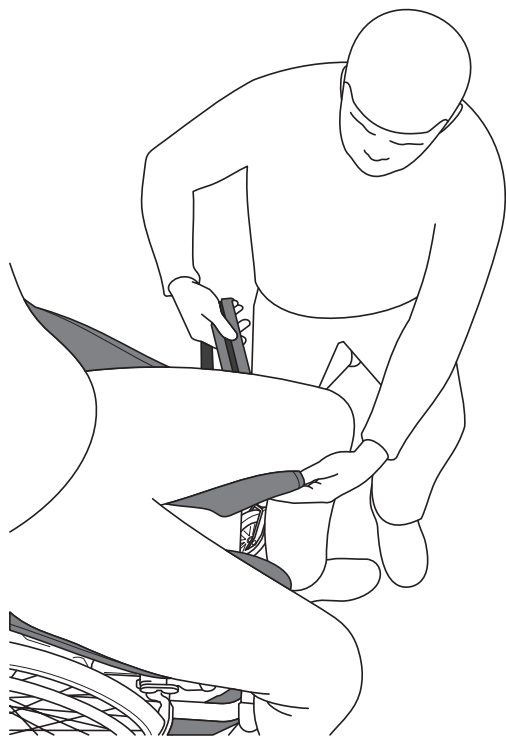



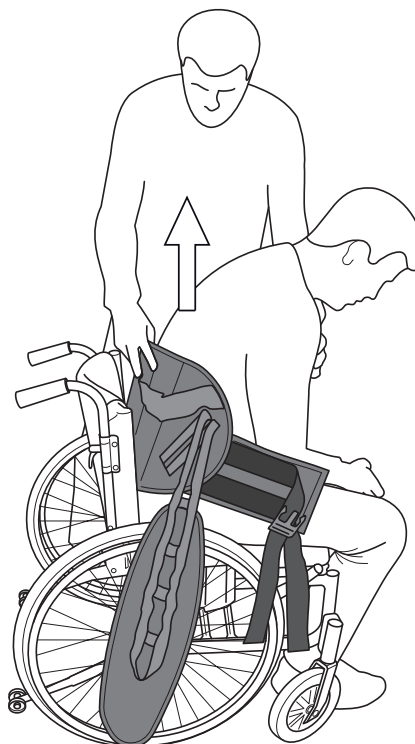







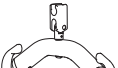
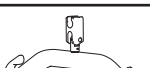
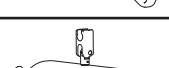
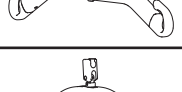

D1. Retire el soporte de la extremidad doblándolo bajo la propia eslinga y el muslo del usuario y sáquelo.

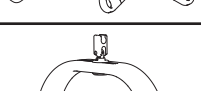

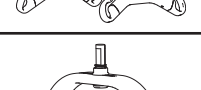
D2. Colóquese cerca de la silla y recline al usuario hacia delante al tiempo que lo sujeta con una mano. Saque la eslinga con la otra mano y recline la espalda del usuario hacia la silla. Si tira de la eslinga hacia arriba demasiado fuertemente, el usuario podría caer hacia delante y lesionarse. Coloque siempre una mano alrededor del usuario.

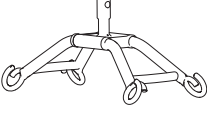
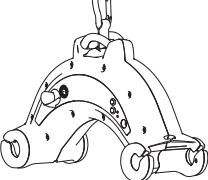
Lista de combinación

Suspension		RgoSling Toilet Lowback / RgoSling Toilet Highback		
		XXS - S	S - L	L - XXL
Mover 180				
	2-pt Small	✓		
	2-pt Medium	✓	✓	
	2-pt Large		✓	
	4-pt Medium	✓	✓	✓
	4-pt Large		✓	✓
Mover 205				
	2-pt Small	✓		
	2-pt Medium	✓	✓	
	2-pt Large		✓	
	4-pt Medium	✓	✓	✓
	4-pt Large		✓	✓
Mover 300				
	4-pt Medium	✓	✓	✓
	4-pt Large		✓	✓
Partner 255				
	4-pt Medium	✓	✓	✓
	4-pt Large		✓	✓

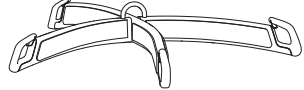
Suspension		RgoSling Toilet Lowback / RgoSling Toilet Highback		
		XXS - XS	S - L	XL - XXL
Smart				
	4-pt Medium	✓	✓	✓
Nomad				
	4-pt Medium	✓	✓	✓
Nova				
	2-pt Small	✓		
	2-pt Medium	✓	✓	
	2-pt Large		✓	
	4-pt Medium		✓	✓
	4-pt Large			✓

Guía de eslingas

El tamaño en cuestión dependerá en parte del peso del usuario, de su actividad y de la circunferencia y el tamaño de su cuerpo. Una carga de trabajo segura (SWL) es de 300 kg.

Size	Weight (Kg)
XXL	230-300
XL	160-240
L	90-160
M	45-95
S	25-50
XS	17-25
XXS	12-17

Solución de problemas

Problema	Causa / acción posibles
La eslinga no se adapta al usuario.	Tamaño de la eslinga incorrecto. Pruebe otro tamaño.
	La eslinga es demasiado pequeña cuando los soportes de las extremidades no alcanzan la mitad del muslo interno y la percha está demasiado cerca de la cara del usuario. Pruebe otro tamaño.
	La eslinga no está bien colocada. Tire de la eslinga suficientemente hacia abajo en la parte posterior cuando la coloque.
Las correas no elevan al mismo tiempo.	Si las correas de la eslinga no se elevan uniformemente, la eslinga podría deslizarse hacia arriba en la parte posterior, lo que podría provocar que el usuario se resbale por la apertura de la eslinga. Asegúrese de que los soportes de las extremidades están colocados correctamente en los muslos.
El usuario se desliza a través / fuera de la eslinga.	La eslinga no está conectada correctamente según la prescripción individual.
	El usuario viste ropa resbaladiza. Cámbiele de ropa o quítele alguna prenda.



Etac A/S
Parallevej 3
DK-8751 Gedved
www.etac.com



molift[®]
by Etac